

Jouni A. Jurvelin

Personal Exposures to Volatile Organic Compounds and Carbonyls: Relationship to Microenvironment Concentrations and Analysis of Sources

Department of Environmental Health
Laboratory of Air Hygiene
National Public Health Institute
Helsinki, Finland
2003

**Personal Exposures to Volatile Organic Compounds and
Carbonyls: Relationships to Microenvironment
Concentrations and Analysis of Sources**

Jouni A. Jurvelin

National Public Health Institute
Department of Environmental Health
Laboratory of Air Hygiene
P.O.Box 95, FIN-70701 Kuopio, Finland

ACADEMIC DISSERTATION

To be presented with the permission of the Faculty of Natural and Environmental Sciences of the University of Kuopio for public examination in Auditorium L21 of the Snellmania building, University of Kuopio, on June 19, 2003, at 12 o'clock noon.

Publisher: National Public Health Institute
Mannerheimintie 166
FIN-00300 Helsinki, Finland
Phone +358-9-474 41
Telefax +358-9-474 48 408

Author's address: Jyväskylä Polytechnic
School of Engineering and Technology
Viitaniementie 1
FIN-40720 Jyväskylä, Finland

Phone +358-14-444 74 07
Telefax +358-14-444 74 84
E-mail jouni.jurvelin@jypoly.fi

Supervisors: Professor Matti J. Jantunen, Ph.D.
National Public Health Institute
Kuopio, Finland

Professor Juhani Ruuskanen, Ph.D.
University of Kuopio
Kuopio, Finland

Docent Matti Vartiainen, Ph.D.
National Product Control Agency for Welfare and Health
Tampere, Finland

Reviewers: Professor Pentti Kalliokoski, Ph.D.
University of Kuopio
Kuopio, Finland

Associate Professor Junfeng Zhang, Ph.D.
University of Medicine and Dentistry of New Jersey
Rutgers University
Piscataway, New Jersey, US

Opponent: Docent Anneli Tuomainen, Ph.D.
Finnish Institute of Occupational Health
Kuopio, Finland

ISBN 951-740-355-0
ISSN 0359-3584

Kuopio University Printing Office, Kuopio, Finland, 2003

Jurvelin Jouni A, Personal Exposures to Volatile Organic Compounds and Carbonyls: Relationships to Microenvironment Concentrations and Analysis of Sources. Publications of the National Public Health Institute A9/2003. 92 pages. ISBN 951-740-355-0, ISSN 0359-3584.

ABSTRACT

Volatile organic compounds (VOCs) and carbonyls are organic air pollutants that create a potential risk to public health. However, the personal exposures related to different microenvironments are not well characterized for these compounds. The aims of the current study were to determine the basic statistics of personal exposure concentrations to VOCs and carbonyls in the Helsinki population and to assess the roles of residential (outdoor and indoor) and workplace concentrations in these exposures. Furthermore, the main sources of VOCs and carbonyls in residential and workplace microenvironments were determined and the roles of these sources in personal exposures of the Helsinki population during 1996-1997 were assessed. The further aim was to identify subcategories of VOCs and carbonyls with similar environmental determinants of personal exposure concentrations.

In EXPOLIS-Helsinki, microenvironment and personal exposure concentrations of 30 target VOCs were assessed over 48-hr sampling periods for 201 randomly selected adults. In addition, a random sub-sample of 15 participants was drawn to assess microenvironment and personal exposure concentrations to 16 carbonyls. The VOC and carbonyl samples were actively collected into Tenax TA adsorbent tubes and Sep-Pak DNPH-Silica cartridges, respectively.

Toluene showed the highest geometric mean personal VOC exposure concentration ($16.3 \mu\text{g}/\text{m}^3$) within the population of Helsinki, followed by m&p-xylenes, d-limonene, hexaldehyde and α -pinene. In the carbonyl study, formaldehyde had the highest personal exposure concentration (GM 18.7 ppb), followed by acetone and acetaldehyde. Geometric mean residential indoor concentrations in Helsinki were higher than outdoor concentrations for all target compounds except hexane. Inside the residences toluene had the highest concentration (GM $14.6 \mu\text{g}/\text{m}^3$) among the VOCs, and formaldehyde (GM 28.3 ppb) among the carbonyls. Geometric mean levels of VOCs and carbonyls were generally higher in the residences than in the workplaces. Residential indoor and workplace concentrations were, compared to residential outdoor air levels, stronger predictors of personal exposure concentrations. In addition, exposures in traffic indicated significant associations with personal exposure concentrations to BTEX-compounds.

The significance of tobacco smoke as a source of VOC exposure of the Helsinki population was demonstrated clearly in the current study. Geometric mean exposures to BTEX-compounds as well as to styrene and trimethylbenzenes were 1.2-1.5 times higher for the population of ETS exposed participants than for those not exposed. The major VOC source categories were different in each microenvironment. The two strongest source factors in the personal exposure concentrations (for participants not exposed to ETS) were linked to traffic related sources. VOC levels in the residential indoor and workplace environments, however, were substantially higher than the levels observed in residential outdoor environments for most traffic related compounds indicating significant additional indoor sources, such as consumer products and building materials for these compounds. Thus, great care must be taken when attributing the magnitudes of personal exposures to specific sources identified in the outdoor environment. Strong inter-compound correlations of carbonyls in residential indoor microenvironments suggested common sources such as cleaning products, fragrances, consumer products and building materials for these compounds. In the workplace environment, the VOC source factor associated with air fresheners (particularly d-limonene concentrations) correlated negatively with formaldehyde, acetaldehyde, benzaldehyde and heptylaldehyde. This finding may indicate indoor air chemistry between terpenes and increased daytime O_3 levels in workplaces of Helsinki.

Personal exposure concentrations to VOCs were, in general, lower in the population of Helsinki compared to those in the North American and Western European populations. Considerable variations in median personal exposure concentrations for the compounds with mainly indoor sources suggested differences in product types and building materials between Finland, Germany and the United States. As a good example, the halogenated compounds that are frequently observed in North American exposure samples were absent in Helsinki. Overall, the findings of the present study showed that accurate estimation of exposures to assess potential health risks requires personal monitoring as data collected in one or two microenvironments could underestimate exposures, and hide significant sources.

To My Family

ACKNOWLEDGEMENTS

This work was carried out in the Air Hygiene Laboratory of the Department of Environmental Health, Finnish National Public Health Institute (KTL, Kuopio) during the years 1996-2003. I express my sincere thanks to the former Director of the Department of Environmental Health, Professor Jouko Tuomisto, for providing the facilities for this study.

I express my deepest respect and gratitude to my principal supervisor, Professor Matti Jantunen, for introducing me to the research of air pollution exposure assessment and for creating a warm scientific atmosphere in his research team. I want to thank for his support and encouragement in the course of this study. It has been an honor to work under his energetic and innovative personal guidance. I want to express my gratitude to my supervisors Professor Juhani Ruuskanen and Docent Matti Vartiainen, for their valuable advice and encouragement during this study.

I want to express my sincere thanks to the pre-examiners of my thesis, Professor Pentti Kalliokoski and Associate Professor Junfeng Zhang, for their positive criticism and advice for the improvement of the thesis manuscript. I wish to express my special thanks to Rufus Edwards, Ph.D., for excellent cooperation in writing manuscripts as well as finally for revision of the language of the thesis.

I am grateful to my nearest colleagues in the EXPOLIS study, Otto Hänninen, Kimmo Koistinen, Ph.D., Anu Kousa, Ph.D., Tuulia Rotko and Anna-Maija Piippo, for their cooperation, valuable advice, encouragement and friendship throughout this study. I also wish to thank the other EXPOLIS collaborators, especially Kristina Saarela, Professor Pertti Pasanen and Sari Alm, Ph.D, for their cooperation, expertise and help during this study.

I wish to express my thanks to the personnel of the School of Engineering and Technology, Jyväskylä Polytechnic, for encouragement and help during this work. I extend my thanks to the entire personnel of the Department of Environmental Health, KTL, and VTT Building and Transport.

I am thankful to all my friends and relatives. Deepest gratitude is due to my parents, Laina and Paavo Jurvelin, and to my brother Jukka and his family, for their encouragement and support throughout my life.

Finally, I owe my dearest thanks to my wife Paula and our daughters Valpuri and Alisa. The love, patience and support of my family have been the basis of this work. To them I dedicate this study.

This study was financially supported by the European Community, the Academy of Finland, National Public Health Institute and the Fortum Foundation.

Jyväskylä, June 2003

Jouni A. Jurvelin

ABBREVIATIONS

ACN	Acetonitrile
AM	Arithmetic Mean
BTEX -Compounds	Benzene, Toluene, Ethylbenzene and Xylenes
CAA	Clean Air Act
CEC	Commission of the European Communities
CO	Carbon Monoxide
DNPH	2,4-Dinitrophenylhydrazine
EXPOLIS	Air Pollution Exposure Distributions within Adult Urban Populations in Europe
ETS	Environmental Tobacco Smoke
FID	Flame Ionization Detector
GC	Gas Chromatograph
GerES II	German Environmental Survey 1990/1992
GM	Geometric Mean
HAP	Hazardous Air Pollutant
HPLC	High-pressure Liquid Chromatograph
IARC	International Agency for Research on Cancer
LOD	Limit of Detection
MEM	Microenvironment Monitor
MSD	Mass Selective Detector
MDF	Medium Density Fiberboard
NKB	Nordic Committee on Building Regulations
NO ₂	Nitrogen Dioxide
NO _x	Nitrogen Oxides
O ₃	Ozone
PCA	Principal Component Analysis
PEM	Personal Exposure Monitor
PM _{2.5}	Particulate Matter in Air with a 50% Cut-off Aerodynamic Diameter of 2.5 µm
QA/QC	Quality Assurance/Quality Control
RPD	Relative Percent Difference
SBS	Sick Building Syndrome
SD	Standard Deviation
SVOC	Semi-volatile Organic Compound

TEAM	The US EPA Total Exposure Assessment Methodology Study
TMAD	Time-activity Diary
TVOC	Total Volatile Organic Compound
US EPA	The United States Environmental Protection Agency
VOC	Volatile Organic Compound
VVOC	Very Volatile Organic Compound
WHO	World Health Organization

LIST OF ORIGINAL PUBLICATIONS

This thesis is based on five original publications, which are referred to in the text by the Roman numerals (I-V). Some previously unpublished results are also presented in this thesis.

- I. Jurvelin J, Edwards R, Saarela K, Laine-Ylijoki J, De Bortoli M, Oglesby L, Schläpfer K, Georgoulis L, Tischerova E, Hänninen O, Jantunen M. Evaluation of VOC Measurements in the EXPOLIS Study. *J of Environmental Monitoring* 2001; 3: 159-165.
- II. Edwards RD, Jurvelin J, Saarela K, Jantunen MJ. VOC Concentrations Measured in Personal Samples and Residential Indoor, Outdoor and Workplace Microenvironments in EXPOLIS-Helsinki, Finland. *Atmos Environ* 2001; 35: 4531-4543.
- III. Edwards RD, Jurvelin J, Koistinen K, Saarela K, Jantunen M. VOC Source Identification from Personal and Residential Indoor, Outdoor and Workplace Microenvironment Samples in EXPOLIS-Helsinki, Finland. *Atmos Environ* 2001; 35: 4829-4841.
- IV. Jurvelin J, Vartainen M, Pasanen P, Jantunen M. Personal Exposure Levels and Microenvironmental Concentrations of Formaldehyde and Acetaldehyde in the Helsinki Metropolitan Area, Finland. *J Air Waste Manage Assoc* 2001; 51: 17-24.
- V. Jurvelin JA, Edwards RD, Vartainen M, Pasanen P, Jantunen M. Residential Indoor, Outdoor, and Workplace Concentrations of Carbonyl Compounds: Relationships with Personal Exposure Concentrations and Correlation with Sources. *J Air Waste Manage Assoc* 2003; 53: 560-573.

CONTENTS

1. INTRODUCTION	15
2. REVIEW OF THE LITERATURE	17
2.1. Characteristics of Volatile Organic Compounds.....	17
2.2. Sources of Volatile Organic Compound Exposures.....	18
2.2.1. Emissions from Ambient Urban Sources.....	18
2.2.2. Emissions from Indoor Sources	20
2.3. Volatile Organic Compound Concentrations	21
2.3.1. Ambient Urban Concentrations	21
2.3.2. Indoor Concentrations.....	23
2.4. Exposures to Volatile Organic Compounds.....	26
2.4.1. Personal Exposure Concentrations	26
2.4.2. Relationships between Personal Exposure and Microenvironment Concentrations	30
2.4.3. Activities Increasing Personal Exposures	31
2.5. Health Effects of Volatile Organic Compound Exposures	34
3. AIMS OF THE STUDY	36
4. MATERIALS AND METHODS	37
4.1. Study Design	37
4.2. Study Location and Target Population.....	38
4.3. Monitoring Methods (I, IV-V)	39
4.3.1. Target Compounds	39
4.3.2. Personal and Microenvironment Measurements.....	42
4.3.3. Sample Analyses.....	45
4.4. Quality Assurance/Quality Control (I, IV-V)	46
4.5. Source Apportionment (III, V).....	48
4.6. Data Analyses.....	49
5. RESULTS	50
5.1. Personal Exposure Concentrations (II, IV-V)	50
5.2. Relationships between Personal Exposure and Microenvironment Concentrations (II, IV-V)	53
5.2.1. Residential Outdoor Environments	53
5.2.2. Residential Indoor Environments	55
5.2.3. Workplace Environments.....	56
5.2.4. Summary of Relationships	57
5.3. Source Apportionment (III, V).....	60
6. DISCUSSION	65
6.1. Personal Exposure Concentrations	65
6.2. Relationships between Personal Exposure and Microenvironment Concentrations ..	67
6.2.1. Residential Outdoor Environments	67
6.2.2. Residential Indoor Environments	68
6.2.3. Workplace Environments.....	69
6.2.4. Summary of Relationships	70
6.3. Source Apportionment	73
7. CONCLUSIONS.....	76
REFERENCES	78

1. INTRODUCTION

Volatile organic compounds (VOCs) are organic pollutants with boiling points from 50-100°C to 240-260°C (WHO, 1989) and inhaled air as a main route of human exposure. Several studies have shown increased indoor concentrations of VOCs when compared to outdoor air levels of these compounds (Lebret et al., 1984, De Bortoli et al., 1984, Krause et al., 1987, Wallace 1987, Brown et al., 1994).

Exposure is "an event that occurs when there is contact at a boundary between a human and the environment with a contaminant of specific concentration for an interval of time" (National Academy of Sciences, 1991). This contact can exist through inhalation, ingestion or penetration of the skin surface. According to the definition, exposure is related directly to the pollutant of interest, to the individual, and to the time and duration of exposure (Lioy, 1990).

Determining the risk posed by environmental pollution to public health requires a knowledge of five fundamental components (the risk model, Figure 1): the sources of pollutants, the transport of pollutants from sources to humans, the exposures of humans to pollutants, the doses received by those who are exposed, and the adverse health effects resulting from the doses (Ott, 1985). As the output of each model's component serves as input to the next, the absence of valid information on any component can impair the ability to make accurate assessments of public health impacts from environmental pollution.



Figure 1. Five components of the risk model (adopted from: Ott, 1985).

Exposure assessment is defined as "determination of the emissions, pathways and transformations of pollutants in order to estimate the concentrations/doses to which humans are or may be exposed" according to the Commission of the European Communities (CEC) Directive 93/67/EEC (CEC, 1993). Moreover, exposure assessment can be used to determine the distributions of exposures within the population and the contribution of various

microenvironments and pathways to the integrated exposure as well as in identifying sub-groups with relatively high exposures (CEC, 1991).

Environmental laws, standards and other regulations have concentrated traditionally on the release of pollution into environment rather than the extent of human exposure caused by the release. For this reason, the amounts of environmental pollutants to which general populations are actually exposed have often been ignored. In addition, non-occupational air pollution regulations have typically acted with respect to outdoor rather than indoor air. This means that toxic pollutants that are emitted from indoor sources have been ignored (Roberts, 1998). However, in some cool climate countries (such as e.g., Finland) people can spend as much as 90% of their daily time in different indoor environments, with the majority spend at home. Thus, human exposure to many air pollutants is dominated by indoor air pollution, which consists of both outdoor air pollution that has penetrated indoors and pollution from either direct indoor sources or pollution generated indoors by different chemical reactions. Although significant associations have been observed between ambient urban air pollutant levels and mortality and morbidity in the populations, most of the exposure occurs in indoor environments (Jantunen, 2001).

The present thesis is based on fieldwork carried out in the Helsinki metropolitan area, Finland, as a part of the European Union 4th Framework RTD (Research, Technological Development and Demonstration) Program funded multi-center study EXPOLIS (Air Pollution Exposure Distributions within Adult Urban Populations in Europe). It presents personal exposure concentrations to VOCs and carbonyl compounds in an urban adult population as well as examines the roles of residential outdoor, residential indoor and workplace concentrations and sources in these exposures. Based on the results from this thesis, the implications of controlling sources in each microenvironment can be examined in relation to controlling personal exposures to VOCs and carbonyl compounds, allowing prioritization of control methods to reduce general population exposures. Furthermore, results from this thesis can be used to identify sub-populations and activities that result in elevated exposure levels to specific VOCs and carbonyls, allowing a prioritization of control approaches for these compounds.

2. REVIEW OF THE LITERATURE

2.1. Characteristics of Volatile Organic Compounds

Organic air pollutants can be separated into four main groups based on their boiling point ranges (WHO, 1989):

1. Very volatile organic compounds (VVOC),
2. Volatile organic compounds (VOC),
3. Semi-volatile organic compounds (SVOC), and
4. Organic compounds associated with particulate matter or particulate organic matter.

This World Health Organization (WHO) categorization is based on compound volatility as it is the most important factor determining the efficiency of different sampling adsorbents to collect organic pollutants from air. According to the classification, VOCs are compounds that have melting points below room temperature and boiling points from 50-100°C to 240-260°C (WHO, 1989).

VOCs are important air pollutants for two distinct reasons. Firstly, some VOCs are together with nitrogen oxides (NO_x) precursors required for the photochemical production of ozone (O_3) and other components of photochemical smog (Manahan, 1994). Secondly, VOCs include species that have individually acute or chronic health effects in humans (WHO, 2000). More than 500 different VOCs have been identified from air of indoor environments (Sheldon et al., 1988). As the number as well as diversity of VOCs in the air can be so large, the concept of total VOCs (TVOCs) has sometimes been used to describe the concentrations of VOC mixtures in the air. There is no standardized monitoring procedure for TVOCs, however, and different ways to determine TVOC have sometimes caused confusion in comparisons of concentrations between separate studies as the TVOC measures for each study have included different levels of different mixtures of VOCs. In addition, a major drawback of the TVOC concept is that no cause-effect relationships exist between TVOC concentration and health effects (Wolkoff, 1995, Andersson et al., 1997, Wolkoff and Nielsen, 2001). Thus, measurements of individual compounds that are expected to have environmental or biological effects should be linked to more specific emission testing of building products or exposure assessment in determining the distributions of VOC exposures in the population.

The concentrations of VOCs are often higher in indoor environments than outdoors. In addition to direct VOC sources, recent studies have shown that chemical reactions of unsaturated organic compounds such as terpenes with oxidants such as O_3 and NO_x may occur indoors to produce a variety of carbonyl compounds (aldehydes and ketones) that may act as airway irritants (Weschler and Shields, 1997, Wolkoff et al., 2000, Wolkoff and Nielsen, 2001).

2.2. Sources of Volatile Organic Compound Exposures

2.2.1. Emissions from Ambient Urban Sources

Globally, the main natural sources of VOCs include forests, wetlands and tundras. The most abundant hydrocarbon in the atmosphere is methane, mainly released as natural gas and produced by the fermentation of organic matter (Manahan, 1994). It is usual to disregard methane from estimates of VOC concentrations, since although methane dominates the other VOCs in ambient urban air it is not toxic at those concentration levels (Colls, 1997). In addition, participation of methane in the formation of photochemical smog is negligible due to its low reactivity. Thus, emissions of methane into the atmosphere are more relevant for global warming issues due to its high warming potential (Houghton et al., 1996).

Main anthropogenic sources of VOCs include industrial processes, fossil fuel combustion in transportation and electricity generation sectors, household products, landfills and waste treatment plants. In many areas gasoline vapor and motor vehicle exhaust are the major sources for most VOCs. For example, in the United States (US) about 85% of outdoor air levels of one carcinogenic VOC, benzene, come from mobile sources and just 15% from stationary sources (Wallace, 1996a). Main anthropogenic sources of benzene in Europe include vehicular traffic (80-85%), chemical industry (1.3-13%), domestic heating (3-7%), fuel distribution (2.6-6%), solvent use (1-4%) and gasoline refineries (0.3-1.5%) (CEC, 1998). Overall, vehicle-related VOC emissions are ubiquitous in urban areas. In addition, solvents from architectural and industrial sources are common but highly variable in most areas, while petrochemical production and oil refining are more specific to certain urban settings with these activities (Watson et al., 2001).

The vast majority of current modes of motor vehicle transport emit air pollutants from the combustion of hydrocarbon fuels. VOCs in polluted ambient air from this sector may be the result of evaporative emissions, tailpipe emissions, or may be produced indirectly by the atmospheric oxidation of the same fuels (Baugh et al., 1987, Calvert and Madronich, 1987, Wixtrom and Brown, 1992). The heavy-duty diesel and light-duty gasoline exhaust profiles are somewhat similar as ethane, acetylene, 1-butene, isobutene, propane, propene, isopentane, pentane, 2,2-dimethylbutane, 2-methylpentane, hexane, benzene, 3-methylhexane, toluene, ethylbenzene, m&p-xylenes, m-ethyltoluene and 1,2,4-trimethylbenzene are the most abundant compounds in both of these emissions. Several of these VOCs are short lived and can be found in the ambient air for example during early morning in areas where pollutants have recently been emitted. Major differences between heavy-duty diesel and light-duty gasoline exhaust profiles include acetylene, isobutene, isopentane, hexane and 2-methylhexane that are most abundant in gasoline exhaust as well as propene, propane, 2,2-dimethylbutane, decane and undecane that are more abundant in diesel exhaust. Evaporative gasoline emissions contain many of the same compounds as gasoline vehicle exhaust. However, combustion products such as ethane and acetylene are depleted from evaporative emissions. Further, evaporative gasoline emissions are depleted of the heavier hydrocarbons (slower volatilization from liquid fuel) and enriched in compounds such as isobutene, butane and isopentane (Watson et al., 2001).

In addition to VOCs, carbonyl compounds have been attracting increasing attention amongst scientists. These compounds are among the most abundant and easily photolyzed compounds in the atmosphere, and for this reason an essential source of free radicals in tropospheric photochemistry. Practically all hydrocarbons in the troposphere are likely to produce carbonyls by photo-oxidation (Carlier et al., 1986).

There are also natural sources that generate VOCs in urban areas through direct emissions and through photochemical oxidation of naturally emitted hydrocarbon precursors (Lloyd et al., 1983, Shepson et al., 1991, Seinfeld and Pandis, 1998). Plants synthesize many organic compounds such as ethene, aldehydes, ketones, alcohols, isoprenene and terpenes as an integral part of their biochemistry. Deciduous trees have found to be mainly isoprene emitters, while conifers favor monoterpenes (Colls, 1997).

2.2.2. Emissions from Indoor Sources

Primary sources of VOCs in indoor environments include outdoor air (penetration from outdoors to indoors) as well as indoor sources such as tobacco smoke, fuel combustion, building materials, furnishing, furniture and carpet adhesives, cleaning agents, ventilation systems, cosmetics and the occupants themselves. Indoor materials used in furnishings can act both as a source as well as a sink capable of absorbing and re-emitting VOCs. Emission rates are specific for each compound and source, and are influenced by factors such as relative humidity, temperature, air exchange rates, occupant activity and the age of materials. Typically no significant differences between VOC concentrations in different rooms of residences have been observed whether there are single or multiple sources, indicating high diffusion and mixing velocity of VOCs in the homes (Hartwell et al., 1992, Humfrey et al., 1996).

According to the United States Environmental Protection Agency (US EPA) TEAM (Total Exposure Assessment Methodology) study, the major VOC exposure sources of non-smoking US populations were air fresheners and household and bathroom deodorizers (Wallace, 1996b). The main VOCs identified in these products were *p*-dichlorobenzene, δ -limonene and α -pinene. Other major VOC sources in the US residences included dry-cleaned clothes, insect repellent products, treated wood products such as furniture and wood paneling, incomplete combustion from cooking or from heating systems and environmental tobacco smoke (ETS) (Moriske et al., 1996).

Benzene, ethylbenzene, trimethylbenzene, toluene, styrene, *m*&*p*-xylenes and *o*-xylene as well as carbonyls formaldehyde and acetaldehyde are examples of compounds that have been identified in cigarette smoke and have been associated with exposure to ETS (Wallace and Pellizzari, 1986, Barrefors and Petersson, 1993, Maroni et al., 1995). According to the German Environmental Survey 1990/1992 (GerES II study), the most important determinant of benzene exposure in non-smoking German populations was the presence of ETS indoors (Hoffmann et al., 2000). Overall, it has been estimated that homes with smokers have median indoor air benzene concentrations about $4 \mu\text{g}/\text{m}^3$ higher than homes without smokers (Wallace et al., 1987a, Krause et al., 1987). In residences without ETS, outdoor air has been a more important source of benzene levels compared to compounds such as toluene and undecane, where residential indoor concentrations are dominated by indoor sources (Wolkoff et al., 1991, Brown and Crump, 1996).

In addition to ETS, other residential indoor sources of styrene include sources such as carpets and adhesives (Wallace et al., 1989, Ong et al., 1993, Daisey et al., 1994). Exposures to C₈-aromatics such as ethylbenzene, m&p-xylenes and o-xylene largely result from typical residential and workplace indoor sources such as emissions from paints, lacquers and printing inks (Hoffmann et al., 2000). In the analysis by Fellin and Otson (1994), the most important factor explaining the variance of indoor VOC concentrations in Canadian residences was dominated by the simultaneous occurrence of the four compounds mentioned above, and was identified to sources such as paints and motor vehicle emissions in outdoor air. Other factors explaining the variance in residential indoor concentrations of target VOCs were identified to the following sources (in order from more to less important): 1) building materials, paints and carpets (decane, 1,2,4-trimethylbenzene and 1,3,5-trimethylbenzene), 2) household products and moth crystals (dichloromethane and 1,4-dichlorobenzene), 3) cosmetics or furniture polish (trichloroethylene and 1,2,4-trichloroethane), 4) vegetation or household air fresheners and cleaning agents (cymene, limonene), and 5) building activities (α -pinene).

Recent studies of the indoor air chemistry of VOC pollutants have shown that chemical reactions of unsaturated organic compounds such as terpenes with oxidants such as O₃ and NO_x occur indoors to produce compounds that were not emitted as primary pollutants in indoor environments (Wolkoff et al., 2000, Wolkoff and Nielsen, 2001). Carbonyl compounds such as formaldehyde and acetaldehyde as well as other C₅-C₁₀ aldehydes are known products of these reactions (Weschler and Shields, 1997, Shaughnessy et al., 2001). In addition, d-limonene has been reported as an important source of fine particulate matter when O₃ is present in indoor environments (Wainman et al., 2000).

2.3. Volatile Organic Compound Concentrations

2.3.1. Ambient Urban Concentrations

Regulation and assessment of air pollution has traditionally focused on ambient environmental levels of pollutants. A good example of this is maybe the most notable legislation ever pertained to air quality, North American Clean Air Act (CAA) of 1970 and its revision in 1990 (US EPA, 1991), which addressed outdoor levels of air pollutants. In addition, the great majority of regulations, laws and standards regarding pollutant emissions for industrial facilities are based on release into ambient air rather than on the extent of

human exposure. Outdoor air concentrations of many air pollutants including a variety of common VOCs are generally considerably lower than indoor levels of these compounds, however, even in heavily industrialized areas or areas with high traffic densities (Wallace, 1987).

“Central sampling stations” or “fixed monitoring stations” located in city centers characterize the actual outdoor air levels of many pollutants around the city and its suburbs quite badly. In contrast to many industrial processes, air pollution from urban traffic is emitted into the air at similar heights as the human breathing zone. In addition, streets and roads in city centers are typically surrounded by high buildings, which may reduce the dispersion of vehicle generated air pollutants by winds. The concentration of vehicle exhaust can be significantly enhanced in “street canyons” with high traffic density as a result of this. Chan et al. (1991a), reported a ratio of 10/5/2 between in-vehicle/pedestrian/fixed monitoring station median concentrations for benzene, toluene, and m&p-xylenes. Moreover, time-averaged concentrations in models have varied by as much as a factor of 2-3 over distances as short as few meters on the road (McHugh et al., 1997).

Benzene is one of the few VOCs that generally show similar or even higher concentrations in ambient urban air compared to levels in indoor environments. In the North American TEAM study, the mean outdoor air concentrations of benzene varied between study locations from 2 to 9 $\mu\text{g}/\text{m}^3$ (Wallace, 1990). According to the position paper of the new European benzene directive (CEC Directive 2000/69/EC, 2000), ambient benzene concentration levels in European city background and center areas vary by approximately 2-10 $\mu\text{g}/\text{m}^3$ and 4-20 $\mu\text{g}/\text{m}^3$, respectively (CEC, 1998). In rural locations these concentrations are typically below 1 $\mu\text{g}/\text{m}^3$. Cocheo et al. (2000), reported that in six European cities (Antwerp, Athens, Copenhagen, Murcia, Padua and Rouen), the Monday to Friday mean ambient benzene concentration ranged from 3.1 $\mu\text{g}/\text{m}^3$ in Copenhagen to 20.7 $\mu\text{g}/\text{m}^3$ in Athens with an average of 8.8 $\mu\text{g}/\text{m}^3$ (Figure 2).

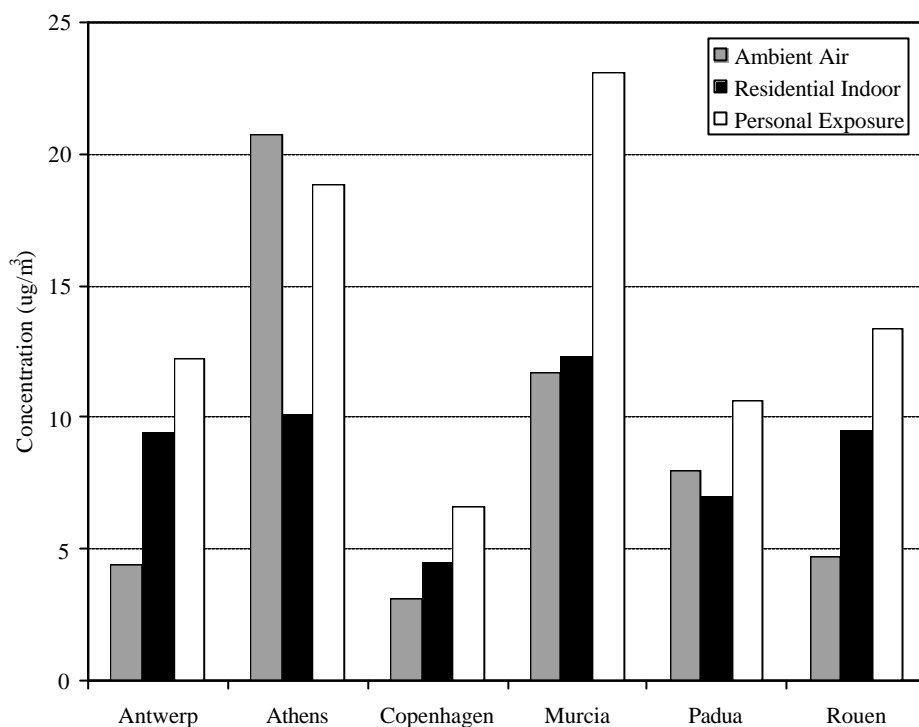

Figure 2. Ambient air, residential indoor and personal exposure Monday-Friday mean concentrations of benzene according to the study carried out in six European cities in 1997-98 (adopted from: Cocheo et al., 2000).

2.3.2. Indoor Concentrations

It has been estimated that in typical non-industrial indoor environments 50-300 different VOCs are continuously present in the air (Møhlhave, 1990). The Working Group on Indoor Air Quality at WHO constructed a data set for air pollutants to represent concentration levels for a “typical-home” (WHO, 1989). Some of these concentrations are shown in Table 1 for selected VOCs. Brown et al. (1994), in a review of 68 indoor VOC studies, concluded that mean concentrations of each VOC in established buildings were generally below $50 \mu\text{g}/\text{m}^3$, with most below $5 \mu\text{g}/\text{m}^3$, while TVOC concentrations were substantially higher indicating a large number of compounds present in these buildings.

Table 1. Median and 90th percentile concentrations ($\mu\text{g}/\text{m}^3$) of selected VOCs in a “typical home” (adopted from: WHO, 1989).

Compound	50% ¹	90% ²
Alkanes		
Decane	10	50
Undecane	5	25
Aromatics		
Benzene	10	20
Toluene	65	150
1,2,4-Trimethylbenzene	5	20
1,3,5-Trimethylbenzene	2	5
m&p-Xylenes	20	40
o-Xylene	5	10
Halogenated		
p-Dichlorobenzene	5	20
1,1,1-Trichloroethane	5	20
Terpenes		
d-Limonene	15	70

¹50th percentile.

²90th percentile.

Several studies have shown increased indoor concentrations of VOCs when compared to outdoor air levels indicating direct emissions of additional indoor sources or indoor chemical formation for these compounds (Lebret et al., 1984, De Bortoli et al., 1984, Krause et al., 1987, Wallace 1987, Brown et al., 1994). Brown et al. (1994), reported that mean residential indoor/outdoor concentration ratios (I/O-ratios) typically range between 3-20 for alkanes, 2-12 for carbonyls, 3-15 for aromatics, and 20-80 for terpenes. Mean I/O-ratios close to 1.0 have been identified for traffic related compounds in rooms facing city streets with high traffic density, while in the rural areas much higher I/O-ratios have been observed for the same compounds (with the exception of benzene) (Ilgen et al., 2001a). Mean I/O-ratios of benzene in Antwerp, Athens, Copenhagen, Murcia, Padua and Rouen ranged between 0.5-2.1 with an average of 1.3 (Cocheo et al., 2000).

Toluene is typically the most predominant VOC observed in residential indoor environments (Brown et al., 1994, Fellin and Otson, 1994, Brown and Crump, 1996). For this compound, indoor activities such as decorating, painting and refurbishment have a far greater influence on indoor concentrations than ventilation, which is partly influenced by climate. Acetone and d-limonene have demonstrated normal residential indoor concentrations in the range of 20-50 $\mu\text{g}/\text{m}^3$, and, in North American homes, 1,1,1-trichloroethane also demonstrated a similar range of indoor concentrations (Brown et al., 1994). Overall, halogenated organic compounds

have been frequently present in North American and Japan residences, but much less common in North European homes (Wolkoff and Nielsen, 2001).

Kostiainen (1995) carried out a study where residential indoor concentrations of 48 VOCs were determined in 50 normal houses (houses, which were more than three years old and no repairs were carried out in the houses during the last 1.5 years, and the people living in the houses had not complained about the odor or other symptoms) and 38 sick houses (houses, in which people complained about the odor or they had symptoms which resembled the Sick Building Syndrome (see section 2.5)) in Helsinki. A summary of the mean and median concentration levels for selected VOCs are presented in Table 2 for the normal houses of the study.

Table 2. Mean and median residential indoor concentrations ($\mu\text{g}/\text{m}^3$) for selected VOCs in 50 normal houses in Helsinki (adopted from: Kostiainen, 1995).

Compound	Mean	50% ¹
Alkanes		
Nonane	3.0	1.5
Decane	3.5	2.3
Undecane	2.2	1.8
Aromatics		
Benzene	4.9	3.1
Toluene	21.3	20.2
Ethylbenzene	3.2	2.4
p-Xylene	7.4	5.8
o-Xylene	2.4	1.8
Styrene	0.8	0.5
Naphtalene	0.4	0.3
Propylbenzene	0.8	0.6
Alcohols		
Phenol	0.9	0.7
Aldehydes		
Hexaldehyde	6.6	5.4
Octylaldehyde	4.6	3.6
Nonylaldehyde	3.6	3.0
Benzaldehyde	2.1	1.8
Halogenated		
1,1,1-Trichloroethane	1.6	1.0
Tetrachloroethene	0.5	0.3
Terpenes		
d-Limonene	14.2	8.8
3-Carene	2.8	1.9
α -Pinene	9.3	7.7

¹50th percentile.

Toluene had the highest median indoor concentration in normal Helsinki residences, followed by d-limonene, α -pinene, p-xylene and hexaldehyde. According to the study, residential

indoor concentrations of VOCs exceeded median levels more often in the sick than in the normal houses. Aromatic hydrocarbons, terpenes, 1,1,1-trichloroethane and tetrachloroethene were compounds that occurred most often with increased concentrations in the sick houses.

In new or renovated buildings, VOCs such as xylenes, ethylbenzene, ethyltoluene, trimethylbenzenes, decane, undecane and α -pinene as well as carbonyls such as formaldehyde and hexaldehyde may be found in concentrations up to 100 times higher than outdoor levels, falling to around 10 times outdoor levels in several months (Wallace, 1991). The main sources for these high concentrations are paints, adhesives and sheet materials as e.g., plywood or vinyl flooring (Wallace, 1996b, Hodgson et al., 2000). Most of the VOC mass emitted by painted materials is emitted in the first few hours or days following application (Tischenor et al., 1990). Material emission rates of most VOCs are greatest for new materials and VOC emissions have been lowest for the new medium density fiberboard (MDF), higher for particleboard, and highest for laminated office furniture (Brown, 1999).

2.4. Exposures to Volatile Organic Compounds

2.4.1. Personal Exposure Concentrations

Although there have been many detailed studies of VOC and carbonyl emissions and concentrations in indoor air which have led to considerable knowledge of compounds emitted by different materials (e.g., Jo et al., 1990, Namiesnik et al., 1992, Fellin and Otson, 1994, Brown et al., 1994, Fortmann et al., 1998, Brown, 1999, Cox et al., 2001, Kim et al., 2001, Won et al., 2001, Yang et al., 2001, Zhu et al., 2001, Chang et al., 2002, Brown, 2002), there have been few population based surveys, both within and between different countries, to determine the extent and magnitude of population VOC exposures to a broad spectrum of compounds. More personal exposure studies have been carried out which have concentrated on exposure of specific sub-populations to one or few individual VOCs, and most have focused on exposure to benzene (e.g., Chan et al., 1991b, Löfgren et al., 1991, Chan et al., 1993, Van Wijnen et al., 1995, Raascou-Nielsen et al., 1997, Cocheo et al., 2000, Ilgen et al., 2001b, Jo and Yu, 2001, Skov et al., 2001).

The largest probability-based VOC exposure study, the American TEAM study, was conducted in North America between 1979 and 1987. This study involved totally about 750

participants representing 750 000 residents of several geographic areas (Pellizzari et al., 1987a, Pellizzari et al., 1987b, Wallace, 1987). The full-scale TEAM study was run in Bayonne-Elizabeth (New Jersey), Baltimore (Maryland), Antioch-Pittsburgh (Pennsylvania), and Los Angeles (California). Sample analysis was carried out for about 20 target compounds and, in addition to personal monitoring, outdoor air samples were collected simultaneously outside each participant's residence. A summary of the median daytime personal exposure concentrations for selected VOCs is presented in Table 3 for the full-scale TEAM study locations.

Table 3. Median daytime personal exposure concentrations ($\mu\text{g}/\text{m}^3$) for selected VOCs in four main TEAM study locations (adopted from: Wallace et al., 1996).¹

Compound	NJ ²	NJ	NJ	CO ³	LA ⁴	LA	LA	LA	MD ⁵
	1981 Fall (n=350)	1982 Summ (n=160)	1983 Wint (n=50)	1984 Spri (n=75)	1984 Wint (n=120)	1984 Spri (n=50)	1987 Wint (n=50)	1987 Summ (n=40)	1987 Spri (n=75)
Alkanes									
Nonane	NM ⁶	NM	NM	NM	NM	NM	3.2	2.3	2.8
Decane	NM	NM	NM	1.0	2.2	1.8	3.0	2.0	3.9
Undecane	NM	NM	NM	1.3	2.8	1.3	3.2	1.9	3.4
Aromatics									
Benzene	12.0	NM	14.0	6.3	15.0	7.2	13.2	7.1	11.2
Ethylbenzene	5.0	4.2	8.2	2.9	8.0	6.0	5.9	3.7	3.9
m&p-Xylenes	14.0	13.0	25.0	10.0	23.0	18.0	31.4	16.0	14.5
o-Xylene	4.4	5.1	9.9	3.6	10.0	4.0	11.4	5.0	3.9
Styrene	2.0	1.2	5.8	0.8	2.3	1.5	2.1	1.0	1.8
Halogenated									
1,1,1-Trichloroethane	11.0	6.6	26.0	5.5	29.0	11.0	14.0	7.7	11.5
Trichloroethene	2.3	3.0	1.7	0.5	2.2	1.2	0.7	0.3	1.1
Tetrachloroethene	8.3	5.9	9.7	2.2	8.2	3.4	5.3	2.3	2.4
Terpenes									
d-Limonene	NM	NM	NM	NM	NM	NM	25.3	4.3	28.9
α -Pinene	NM	NM	NM	1.0	1.9	1.6	2.8	1.2	2.6

¹Shown concentrations are population-weighted values and refer to the estimate for the target population.

²Elizabeth and Bayonne, NJ.

³Contra Costa County (Antioch and Pittsburgh), CA.

⁴Los Angeles, CA.

⁵Baltimore, MD.

⁶Not measured.

The highest median personal exposure concentrations in the TEAM study were observed for m&p-xylenes (ranging from 10.0-31.4 $\mu\text{g}/\text{m}^3$ between study locations and seasons), 1,1,1-trichloroethane (5.5-29.0 $\mu\text{g}/\text{m}^3$), benzene (6.3-15.0 $\mu\text{g}/\text{m}^3$) and d-limonene (4.3-28.9 $\mu\text{g}/\text{m}^3$).

The largest probability-based VOC exposure study carried out in Europe, before EXPOLIS, was the GerES II study. This study was conducted in 1990-1991 and included a sample of

113 adults from 36 sample locations in Western part of Germany with one week personal exposure sampling by using passive OVM-3500 diffusive samplers (Hoffmann et al., 2000). A summary of the geometric mean, median and 95th percentile personal exposure concentrations of West-Germans to selected VOCs are shown in Table 4.

Table 4. Geometric mean, median and 95th percentile personal exposure concentrations ($\mu\text{g}/\text{m}^3$) to selected VOCs in West-Germany (adopted from: Hoffmann et al., 1996).

Compound	GM ¹	50% ²	95% ³
Alkanes			
Hexane	10.3	9	40
Nonane	3.3	3	26
Decane	5.2	5	41
Cyclohexane	3.8	3	20
Undecane	5.2	4	29
Aromatics			
Benzene	10.5	11	32
Toluene	73.9	69	382
Ethylbenzene	8.5	7	106
m&p-Xylenes	19.9	16	283
o-Xylene	6.5	5	67
Styrene	2.1	2	8
Naphtalene	2.1	2	4
Propylbenzene	2.2	2	8
Trimethylbenzenes	7.3	7	44
Alcohols			
2-Propanol	39.1	40	326
2-Methyl-1-propanol	1.6	<1	23
1-Butanol	2.0	<1	31
2-Ethyl-1-hexanol	3.0	4	14
Alkanals/Alkanons			
Hexaldehyde	1.1	<1	6
Methyl-ethyl-ketone	5.1	4	92
Halogenated			
Trichloroethene	1.2	<1	8
Tetrachloroethene	2.0	2	22
1,1,2-Trichloroethane	<1.0	<1	<1
Terpenes			
d-Limonene	34.1	32	155
3-Carene	3.4	3	30
α -Pinene	6.7	5	74

¹Geometric mean.

²50th percentile.

³95th percentile.

Toluene, which was not sampled in the TEAM study, had the highest median and geometric mean personal exposure concentrations in Germany. The next two compounds in the rank were 2-propanol and d-limonene. Toluene also had the highest personal exposure and residential indoor concentrations in other studies, and is frequently used as a solvent in paints,

lacquers, printing inks, adhesives and other household products for indoor use (Proctor et al., 1991, Fellin and Otson, 1994, Brown and Crump, 1996, Hoffmann et al., 2000).

Many compounds as e.g., nonane, benzene, ethylbenzene, m&p-xylenes, o-xylene and styrene showed quite similar median population exposure levels between North America and Western Europe. Median exposures to halogenated compounds, however, were higher in North America and these compounds were observed more frequently in the TEAM study samples when compared to the GerES II study. Relatively high concentrations of halogenated compounds have been found in many common household and automotive products including oils, greases and lubricants, household cleaners and polishes, paints, and fabric and leather treatments used in North America (Sack et al., 1992). In the indoor air study of office buildings located in the San Francisco bay area (Northern California, US), “dry cleaning” was identified as the major indoor source of these compounds (Daisey et al., 1994).

The ranges of personal air exposures have varied for many compounds by factors of more than 1 000 to 10 000 in North America (Wallace, 1996b), indicating the important role of personal activities in human VOC exposures. This was also the case in the GerES II study as the 95th percentile exposure concentrations were much higher compared to median or geometric mean values for most compounds (Table 4). Exposure to certain chemicals can be strongly associated with factors as smoking, occupation and other characteristics or activities. For example, people living in urban areas with high traffic densities have shown higher exposures to traffic related VOCs such as BTEX-compounds (benzene, toluene, ethylbenzene and xylenes) compared to people living in rural areas. In Germany, geometric mean personal exposure concentrations of non-smoking persons living in rural areas near the city of Hannover were 2.9, 2.4 and 7.7 $\mu\text{g}/\text{m}^3$ for benzene, ethylbenzene and combined xylenes, respectively. Corresponding data for non-smokers living in the city center were 4.0, 2.8 and 9.7 $\mu\text{g}/\text{m}^3$ (Ilgen et al., 2001b). In a Danish exposure study carried out for children aged between 4 and 12 years, median personal exposure concentrations of children living in rural areas near the city of Copenhagen were 4.5, 20 and 13 $\mu\text{g}/\text{m}^3$ for benzene, toluene and xylenes, respectively. Corresponding data for children living in the city of Copenhagen were 5.4, 27 and 17 $\mu\text{g}/\text{m}^3$ (Raaschou-Nielsen et al., 1997). Further discussion of the impact of personal activities on VOC exposures may be found in section 2.4.3.

The global average exposure concentration to benzene has been assessed at around 15 $\mu\text{g}/\text{m}^3$ in North America (Wallace, 1996a). For non-smoking adult volunteers in 6 different

European cities (Antwerp, Athens, Copenhagen, Murcia, Padua and Rouen), mean personal exposure concentrations to benzene ranged from 6.6 $\mu\text{g}/\text{m}^3$ in Copenhagen to 23.1 $\mu\text{g}/\text{m}^3$ in Murcia (Figure 2). In West Germany, a geometric mean benzene exposure level of 10.5 $\mu\text{g}/\text{m}^3$ was observed (Hoffmann et al., 2000) - in East Germany, even lower levels (5.2-5.9 $\mu\text{g}/\text{m}^3$) were found (Ullrich et al., 1996).

2.4.2. Relationships between Personal Exposure and Microenvironment Concentrations

Outdoor sources often have minor impact on total daily population exposure to a given pollutant as people spend much larger amounts of time indoors. In North America, traditional outdoor sources such as motor vehicles (in-vehicle exposure not included) and industry (including petrochemical plants) have contributed 20-25% of total exposure of the population to most common VOCs in the air (Wallace, 1991). In addition, even in heavily industrialized areas or city centers with high traffic densities, these sources have typically had only a small effect on personal VOC exposure levels in the population.

Median personal exposure concentrations typically exceed median outdoor air concentrations by factors of 2-5 for many VOCs (Wallace, 1991, Wallace, 1996b). In the Los Angeles TEAM study, personal exposure/outdoor air mean concentration ratios (P/O-ratios) ranged from 4.4-6.7 for three alkanes (nonane, decane and undecane), 2.5-3.4 for five aromatics (benzene, ethylbenzene, m&p-xylenes, o-xylene and styrene), and 2.8-9.1 for two halogenated compounds (trichloroethane and tetrachloroethene) during the winter period of the study (Wallace et al., 1991). Moreover, for the summer period the ratios were even higher: 12.5-17.2 for alkanes, 2.7-5.8 for aromatics and 7.2 for tetrachloroethene (trichloroethane was not sampled during the summer). These seasonal differences were mainly explained by the systematically lower outdoor air concentrations observed in Los Angeles during the summer.

A major impact of road traffic emissions on human air pollution exposure can occur inside those buildings that line city streets where indoor concentrations of pollutants are determined mainly by the high outdoor concentration adjacent to windows and doors. In Hannover (Germany), the mean P/O-ratios of BTEX-compound concentrations were smaller than 1.0 (toluene 1.1) for urban areas with high traffic density (Ilgen et al., 2001b). In contrast,

personal exposure concentrations in rural areas were significantly higher than outdoor air concentrations (factor 2.5-9.7) demonstrating the importance of indoor sources in exposures to these compounds. Geometric mean concentrations of BTEX-compounds in the outdoor air of the city streets exceeded those in the rural area by a factor of 9-15 (Ilgen et al., 2001a).

The mean benzene P/O-ratios for non-smoking adult volunteers in six different European cities (Antwerp, Athens, Copenhagen, Murcia, Padua and Rouen) varied from 0.9 (Athens) to 2.9 (Rouen) (Cocheo et al., 2000). In the TEAM study, mean benzene P/O-ratios varied from 1.8 to 4.0 between the study locations (Wallace, 1990).

Residential indoor air is the most important determinant of personal exposure to many VOCs as people spend about 80-90% of their time indoors and most of this at home (Schwab et al., 1990, Wallace, 1993, Brown et al., 1994, Ott, 1995). Mean personal exposure concentrations, however, often exceed mean residential indoor air concentrations for some VOCs indicating the important role of personal activities as e.g., smoking, commuting and occupational exposure as an additional source of personal VOC exposure. In the Los Angeles TEAM study, mean personal exposure/residential indoor air concentration ratios (P/I-ratios) ranged between 1.2-1.5 for alkanes (nonane, decane and undecane), 1.3-2.0 for aromatics (benzene, ethylbenzene, m&p-xylenes, o-xylene and styrene), and 1.7-1.8 for halogenated compounds (trichloroethane and tetrachloroethene) during the winter period of the study (Wallace et al., 1991). In six European cities (Antwerp, Athens, Copenhagen, Murcia, Padua and Rouen), mean P/I-ratios of benzene ranged between 1.3 in Antwerp to 1.9 in Athens and Rouen with an average of 1.6 (Cocheo et al., 2000). In Germany, mean P/I-ratios for BTEX-compounds were found to range between 1.1-1.6 for non-working and in 1.3-2.1 for working persons, indicating that non-working people spend most of their daily time inside their own residences (Ilgen et al., 2001b).

2.4.3. Activities Increasing Personal Exposures

Personal exposures for many VOCs, especially compounds associated with traffic emissions, can be higher than levels in the homes, the workplaces and in outdoor air in their immediate environment (Wallace et al., 1989, Ilgen et al., 2001b). Different personal activities such as e.g., smoking, driving car, painting, use of deodorizers, use of engine cleaner or household cleaning, visiting dry cleaners, washing dishes or clothes, swimming in a pool, auto repair or

pumping car as well as many tasks in many occupations have resulted in 10-100 –fold increases in daily exposures to the specific VOCs associated with these activities (Wallace et al., 1989). The following are examples of activities that increase personal VOC exposures:

Occupational Exposure. There are a wide variety of VOC sources associated with different occupations. Clearly there are also tasks and occupations that may lead to exceptional exposures to specific compounds that are not found in the majority of workplaces. Thus, the contribution of occupational exposure to the overall exposure of the individual is only discussed here in general manner. In the GerES II study, the most important microenvironments contributing to personal exposures to C₈- and C₉-aromatics were occupational environments and the main exposure factors for these VOC groups were factors such as “spending time in workshops and warehouses” and “the occurrence of paints or lacquers at the workplace” (Hoffman et al., 2000). In the study by Ilgen et al. (2001b), the workplace was the second most important microenvironment (residential indoor was the first) contributing to the total BTEX-exposure of the working participants of the study (mostly office workers). Personal exposure concentrations were found to be 1.2-1.4 times (toluene: 2.2) higher than the concentrations in the workplace. The correlation coefficients between personal exposure and workplace concentrations ranged between 0.24-0.56 for the compounds sampled.

Not surprisingly, workers who work near VOC sources, motor vehicle exhausts or gasoline vapor emissions (e.g., traffic police officers, taxicab drivers, parking garage attendants, service station attendants, roadside storekeepers and underground storekeepers) are exposed to highly-elevated VOC levels during their work-time (Jo and Song, 2001). For example, Jo and Yu (2001) assessed work-time personal exposure concentrations of taxicab drivers to six selected aromatic VOCs (benzene, toluene, ethylbenzene, m&p-xylenes and o-xylene) in Taegu, Korea, and reported that exposure levels of taxicab drivers exceeded those of an unemployed reference group.

Active Smoking. Tobacco smoke includes hundreds of different VOCs, and mainstream tobacco smoke is the main source of exposure to both benzene and styrene (Wallace et al., 1987a). In North America, 50 million smokers are exposed to about half of the total nationwide “exposure budget” for benzene (Wallace, 1990). In Los Angeles, daytime geometric mean personal exposure concentrations to benzene were 21.3, 16.6 and 9.2 $\mu\text{g}/\text{m}^3$ for smokers, ETS exposed and persons not exposed to ETS, respectively (Hartwell et al.,

1992). In addition, the exposure levels of three other smoking related VOCs (ethylbenzene, m&p-xylenes and octane) were 1.4-2.0 times higher for ETS exposed participants (including smokers) than for those not exposed. Personal exposure concentrations to benzene were 1.7-2.4 times higher for smokers compared to non-smokers in Europe (Hoffmann et al., 1996).

Time Spent in Traffic Microenvironments. High concentrations of traffic related VOCs have been observed in motor vehicle cabins with toluene as the most abundant compound. In addition, personal exposures to benzene, o-xylene, ethylbenzene, m&p-xylenes, decane and undecane have been associated with driving a car (Wallace et al., 1989). Mean concentrations of benzene in private cars during commuting have ranged between 12-248 $\mu\text{g}/\text{m}^3$ among different cities around the world (Chan et al., 1991a, Chan et al., 1991b, Weisel et al., 1992, Chan et al., 1994, Dor et al., 1995, Jo and Choi, 1996). The difference between in-vehicle VOC levels among cities may be related to differences in traffic along commuting routes as well as seasonal and regional differences in ambient temperature and gasoline formulation. Warmer temperatures will obviously increase the vaporization of compounds such as benzene, toluene, ethylbenzene, m&p-xylenes and o-xylene from fuel tanks of vehicles.

In-vehicle concentrations for urban routes have been higher than those on the interstate routes for most traffic related VOCs (Chan et al., 1991a, Chan et al., 1991b) and were explained by such factors as traffic density, lower vehicle speeds and lower atmospheric dispersion rates. Large variations in day-to-day concentrations along a single route, however, also have been observed (Weisel et al., 1992). The highest VOC exposures are associated with commuting by private car compared to bus, subway, train, walking or biking (Chan et al., 1991a, Löfgren et al., 1991, Chan et al., 1993, Van Wijnen et al., 1995). Overall, time spent in traffic when commuting to work in cars has typically contributed 10-30% of the daily personal exposures to BTEX-compounds in non-smoking populations (Chan et al., 1991a, Weisel et al., 1992, Dor et al., 1995, Hoffmann et al., 2000, Ilgen et al., 2001b).

Refueling. Although refueling is an activity that needs only a short time (around one to two minutes), the effect on cumulative exposures during a relative short period, e.g., 12 hr, can sometimes be considerable. Benzene concentrations as high as 2.1 mg/m^3 have been observed at service stations during vehicle refueling (Saarinen, 2002). However, exposures of refueling customers can be reduced effectively with the installation of Stage II vapor recovery systems (CEC Directive 63/94/EC, 1994). According to the study by Saarinen (2002), the mean

benzene concentration during vehicle refueling was reduced at the Stage II service station to $<0.5 \text{ mg/m}^3$.

Painting and Other Renovation Activities. Painting and other renovation activities can result highly elevated personal exposures to some aromatic and aliphatic VOCs. For persons taking part in these activities, 9 hr average exposure levels to compounds such as m&p-xylenes, o-xylene, ethylbenzene, decane and undecane were found to be elevated by as much as 2 orders of magnitude from "normal" exposure levels (Wallace et al., 1989). The occurrence of paints and lacquers, the use of adhesives and renovation or painting in the person's surroundings have been found to be significant predictors for personal exposure to C₈- and C₉-aromatics (Hoffmann et al., 2000).

Use of Room Air Deodorizers and Personal Cosmetics and Soaps. In North America, major personal exposure to p-dichlorobenzene was found to be associated with the use of deodorizers (Wallace et al., 1989). In addition, α -pinene, d-limonene and 3-carene are commonly found in many cosmetics, soaps and air fresheners (Knöppel and Schauenburg, 1989, Cooper et al., 1995).

2.5. Health Effects of Volatile Organic Compound Exposures

The US CAA Amendments of 1990 listed 189 hazardous air pollutants (HAPs) to be controlled under Title I, Part A, Section 112 (US EPA, 1991). 172 of these HAPs are organic chemicals or mixtures of organic chemicals, which cover many chemical classes with varying volatility, polarities, reactivity etc. Overall, exposure to organic air pollutants can cause both acute and chronic health effects in humans (WHO, 2000). Acute effects caused by exposure to relative high concentrations include eye and respiratory tract irritation. At higher concentrations many of the VOCs are potential narcotics and can cause acute central nervous system responses such as dizziness, headaches and loss of short-term memory as well as liver and kidney damage (Maroni et al., 1995).

It is important to note that VOC concentrations normally found in residential indoor or ambient air are much lower than those that would cause acute health effects in humans. However, there has been reported a high incidence of minor but discomforting illnesses such as coughing, sore throat, runny nose and headache especially in well controlled indoor

environments such as office buildings. The phenomenon is called "Sick Building Syndrome (SBS)" and it has been assumed to be a compound response related to air quality as well as to other factors such as room temperature, air humidity and air-change rates (Colls, 1997). Indoor VOCs can provoke some of the symptoms typical of SBS (Maroni et al., 1995). Overall, it has been assumed that there exist some cause-effect relationships between typical indoor VOC concentrations and health effects, partly on the basis of human exposure studies carried out at concentrations orders of magnitude higher (Wolkoff and Nielsen, 2001).

Among VOCs, benzene and vinyl chloride are compounds of particular concern because they are known human carcinogens. The following VOCs and carbonyls with suspected chronic health effects in humans are all known animal carcinogens: formaldehyde, carbon tetrachloride, chloroform, trichloroethylene, tetrachloroethylene and *p*-dichlorobenzene. In addition, 1,1,1-trichloroethane, styrene, α -pinene and benzaldehyde are known mutagens. Acetaldehyde is the precursor of peroxyacetylnitrate, which is a suspected carcinogen. Other VOCs such as octane, decane and undecane are possible co-carcinogens (Maroni et al., 1995).

VOCs and NO_x are precursors of tropospheric O_3 and other photochemical pollutants (Sillmann, 1999). Tropospheric O_3 has been shown to have an additive effect on asthma symptoms (Romieu et al., 1996) and ambient air O_3 levels have been associated with an increase in emergency hospital respiratory admissions (Schwarz, 1996, Spix et al., 1998). In addition to outdoor environments, reactions of unsaturated organic compounds with O_3 and NO_x in indoor environments can produce irritant compounds including a variety of different aldehydes (Weschler and Shields, 1997, Wolkoff et al., 2000, Wolkoff and Nielsen, 2001).

3. AIMS OF THE STUDY

The aims of the current study were:

1. Determine basic statistics to describe personal exposure concentrations as well as residential outdoor, residential indoor and workplace concentrations of VOCs and carbonyls in Helsinki, Finland (I, II, IV, V).
2. Assess roles of different microenvironments in these exposures (II, IV, V).
3. Assess sources of VOCs and carbonyls in residential outdoor, residential indoor and workplace microenvironments as well as roles of these sources in personal exposures of the Helsinki population (III, V).
4. Identify subcategories of VOCs and carbonyls with similar environmental determinants of personal exposure concentrations (III, V).

4. MATERIALS AND METHODS

4.1. Study Design

This thesis is based on fieldwork carried out in the Helsinki metropolitan area, Finland, from fall 1996 to fall 1997 as a part of the European multi-center EXPOLIS study. The purposes of the EXPOLIS study were to measure the exposures of adult urban populations in Europe to major air pollutants and determine key parameters affecting these exposures (Jantunen et al., 1998, Jantunen et al., 1999). The air pollutants included in the study were nitrogen dioxide (NO₂), carbon monoxide (CO), fine particles (PM_{2.5}) and VOCs (Rotko et al., 2000a, Edwards and Jantunen, 2001, Koistinen et al., 2001, Kousa et al., 2001, Rotko et al., 2001, Kousa et al., 2002, Koistinen et al., 2003, I-III). A further aim of the study was to improve environmental health risk assessment and management by developing models and techniques for assessing and predicting consequences of alternative urban development policies on air pollution exposures (Jantunen et al., 1998, Jantunen et al., 1999).

In addition to Helsinki, other urban areas selected for the EXPOLIS were Athens (Greece), Basel (Switzerland), Grenoble (France), Milan (Italy) and Prague (The Czech Republic), to represent different European regions, city sizes and air pollution situations. Exposure related background information was collected for each study participant using questionnaires (Jantunen et al., 1998, Jantunen et al., 1999). Time-activity diaries (TMADs) with a 15 minute time resolution were used to collect time-activity information. As the EXPOLIS was a multi-center study where common sampling methods and laboratory analysis techniques were used (except for VOCs in Basel), carefully planned quality assurance and quality control (QA/QC) procedures were performed to strengthen and simplify the interpretation of observed air pollutant levels between personal exposure and microenvironment samples as well as between participating centers (Jantunen et al., 1998, Koistinen et al., 1999, I).

In the EXPOLIS-Helsinki VOC study, microenvironment and personal exposure concentrations of 30 target VOCs were assessed over 48-hr sampling periods for 201 randomly selected adults (25-55 years of age) living in the Helsinki metropolitan area. A sub-sample of 15 participants was drawn at random for assessment of microenvironment and personal exposure concentrations to 16 carbonyl compounds (EXPOLIS-Helsinki carbonyl study) in addition to the other VOC measurements (IV-V).

4.2. Study Location and Target Population

The population of the Helsinki metropolitan area (referred to as “Helsinki” later in this thesis) is about 900 000 inhabitants, which actually covers four different cities located side by side (Helsinki, Espoo, Vantaa and Kauniainen). The majority of the metropolitan’s population works in offices and service industries, but engineering, electronics, shipbuilding as well as wood and food processing are also important employers of the area.

Helsinki is located on the Gulf of Finland. The climate of the city is typical northern European climate: mean temperature during the wintertime is below 0°C and the ground is covered with ice and snow. During summer months it gets much warmer and in July the mean temperature is around +17°C.

Helsinki presents an opportunity for the study of urban air pollutants related to motor vehicle as well as indoor sources and their contribution to personal exposures as the local background pollutant sources are typically lower than in many other European cities (Salonen, 1991). Most of the area's buildings have heating systems supplied by co-generating power plants via district heating networks of hot water pipes and the numbers of homes with gas cooking appliances as well as attached garages are very low. For this reason, many previously identified indoor sources of combustion-derived air pollutants are not present in the majority of Helsinki homes, which facilitates the study of relative contributions of other indoor sources.

In EXPOLIS-Helsinki, a base sample of the target population was formed by a random draw of 2523 adults (25-55 years of age) from the population census of Helsinki. A short screening questionnaire was filled in and returned by 75% (1881) of the base population sample adults. Sub-samples of 1) 201 participants for measurement of VOC exposures and 2) 234 participants for 48-hr TMADs and extensive exposure questionnaires, were drawn at random from these 1881 study respondents (Jantunen et al., 1998). In addition to the EXPOLIS-Helsinki VOC study with 201 participants, a sub-sample of 15 participants was drawn at random from study respondents for measurement of carbonyl compound exposures (EXPOLIS-Helsinki carbonyl study).

Detailed evaluation of sampling bias between study respondents and the population of Helsinki are reported by Rotko et al. (2000b), and Oglesby et al. (2000). Overall, the

population sample of 201 participants in the EXPOLIS-Helsinki VOC study was representative of the target population in Helsinki. The population sample of 15 participants of the EXPOLIS-Helsinki carbonyl study was chosen randomly from the representative group of 1881 study respondents. Some characteristics of this sub-sample are presented and compared to 1881 respondents of the Helsinki base sample in IV; Table 1.

The sampled workplaces in the EXPOLIS-Helsinki study were mostly office type buildings (61%) located in downtown area of the city (53%). 17% of the sampled workplaces were industrial buildings and 5% single family attached or detached houses. 27% of the sampled workplaces were located in suburban areas and 13% in industrial areas (Jantunen et al., 1999).

4.3. Monitoring Methods (I, IV-V)

4.3.1. Target Compounds

Analysis of VOCs measured in EXPOLIS-Helsinki focused on a core set of 30 target compounds selected on the basis of their environmental and health significance and utility as markers of pollutant sources (Jantunen et al., 1998). In the EXPOLIS-Helsinki carbonyl study, 16 carbonyl compounds were analyzed from the samples. A summary of target compounds is shown in Table 5. Three carbonyls – benzaldehyde, hexaldehyde (hexanal) and octylaldehyde (octanal) – were common for both datasets. As the number of study participants as well as monitored microenvironments was higher in the EXPOLIS-Helsinki VOC study, levels of these three compounds are reported for the VOC analysis in this thesis. The results from the VOC measurement methods and those from the carbonyl measurement methods (see section 4.3.2) showed significant correlation ($p < 0.001$) for these three carbonyl compounds: $r = 0.79$ ($n = 19$) for benzaldehyde, $r = 0.90$ ($n = 47$) for hexaldehyde, and $r = 0.64$ ($n = 47$) for octylaldehyde.

Eleven target compounds of the EXPOLIS-Helsinki VOC study and four of the EXPOLIS-Helsinki carbonyl study are HAPs incorporated into North American CAA Amendments (US EPA, 1991). Benzene and styrene are IARC (International Agency for Research on Cancer) classified carcinogens (class I and class IIB, respectively). 2-buthoxyethanol and d-limonene are skin contact allergens (class III and IIB, respectively) (NKB, 1994) and styrene, 2-

ethylhexanol, phenol, 2-butoxyethanol, hexaldehyde and benzaldehyde are mucous membrane irritants. Formaldehyde is a suspected human carcinogen and acetaldehyde is the precursor of peroxyacetylnitrate, which is a suspected carcinogen. Methyl-ethyl-ketone is a suspected teratogen and benzaldehyde is a known mutagen. Overall, at high concentrations, most carbonyl compounds cause acute irritation effects in humans.

Table 5. Target compounds of the EXPOLIS-Helsinki VOC (n=201) and carbonyl (n=15) studies with CAS-numbers.

EXPOLIS-Helsinki VOC Study		EXPOLIS-Helsinki Carbonyl Study	
Compound	CAS-number	Compound	CAS-number
Hexane	110-54-3	Formaldehyde ¹	50-00-0
Nonane	111-84-2	Acetaldehyde ¹	75-07-0
Decane	124-18-5	Acetone	67-64-1
Undecane	1120-21-4	Propionaldehyde ¹	123-38-6
Cyclohexane	110-82-7	Methy-ethyl-ketone ¹	78-93-3
Benzene ¹	71-43-2	Butyraldehyde	123-72-8
Toluene ¹	108-88-3	Benzaldehyde	100-52-7
Ethylbenzene ¹	100-41-4	2-Pentanone	107-87-9
m&p-Xylenes ¹	108-38-3	Valeraldehyde	110-62-3
o-Xylene ¹	95-47-6	3-Methyl-2-pentanone	565-61-7
Styrene ¹	100-42-5	2-Hexanone	591-78-6
Naphtalene ¹	91-20-3	Hexaldehyde	66-25-1
Propylbenzene	103-65-1	Heptylaldehyde	111-71-6
Trimethylbenzenes	95-63-6	Octylaldehyde	124-13-0
2-Methyl-1-propanol	78-83-1	Nonylaldehyde	124-19-6
1-Butanol	71-42-0	Decylaldehyde	112-31-2
2-Ethylhexanol	104-76-7		
Phenol ¹	108-95-2		
1-Octanol	111-87-2		
2-Buthoxyethanol	111-76-2		
Hexaldehyde	66-25-1		
Benzaldehyde	100-52-7		
Octylaldehyde	124-13-0		
Trichloroethene ¹	79-01-6		
Tetrachloroethene ¹	127-18-4		
1,1,2-Trichloroethane ¹	79-00-5		
d-Limonene	138-86-3		
1-Methyl-2-pyrrolidinone	872-50-4		
3-Carene	13466-78-9		
α -Pinene	80-56-8		

¹Hazardous air pollutant to be controlled under the US CAA (US EPA, 1991).

4.3.2. Personal and Microenvironment Measurements

Personal exposure and microenvironment concentration measurements were carried out by personal exposure (PEMs) and microenvironment monitors (MEMs), respectively. PEMs, carried by each participant for 48 hr, were packed into a sealed aluminum briefcase (Figure 3).



Figure 3. The personal exposure monitor (PEM) developed for the EXPOLIS study. Tenax TA VOC sampling line is in the middle of the case. PM_{2.5} cyclone with a filter holder is in the back left corner, pump in the middle, and battery holder in the back right corner. CO monitor is in the front left corner.

Aluminum was chosen because it is lightweight, durable and free of VOC emissions. The study participants were instructed to keep the PEM with them when moving and within arm's

reach (e.g., on table or seat) when in one place (work, home, etc.). If the participants found the noise level of the PEM intolerable while sleeping, they were instructed to locate it in the next room, and to write a note of this into the TMAD.

MEMs were packed into sealed containers made of MDF board with low-emission paint (Figure 4). No significant emissions of VOCs were measured during testing of container material at VTT Chemical Technology (Espoo, Finland).



Figure 4. The microenvironment monitor (MEM) developed for the EXPOLIS study. Tenax TA VOC sampling tube is in the middle of the box. The $PM_{2.5}$ impactor is above the box, two filter holders are inside the box, the charger is at the bottom, and the pump is outside the box. The pump was placed inside the lower part of the box connected to the tubing, and the doors were closed during runs.

The vacuum of the PM_{2.5} sampling pump was used to draw the VOC and carbonyl samples via T-joints for both personal (pump: Buck IH, A.P. Buck Inc.) and microenvironment sampling (pump: PQ100, BGI Inc.) (Figure 5).

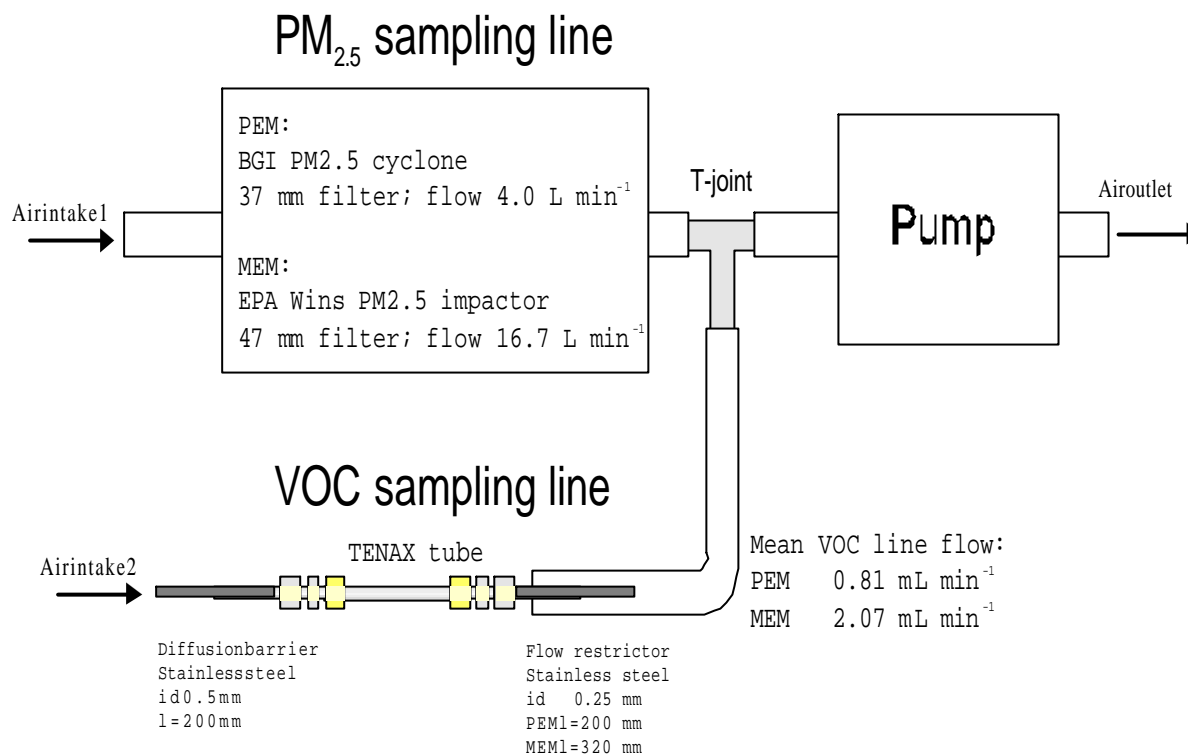

Figure 5. Layout of PM_{2.5} and VOC sampling procedure using a common pump for both samples.

The MEM pumps were programmed to run in the home environments during non-working hours (simultaneous indoor and outdoor sampling) and at the workplaces during working hours according to information given by each participant. Personal exposure sampling times were approximately 48 hr, but microenvironment sample collection times varied depending on the schedule of each participant, typically 2 * 13-15 hr in residential environments and 2 * 7-9 hr in workplaces.

Airflow rates were measured shortly before and after each sampling period with a bubble flow meter (Mini Buck Calibrator M-1, A.P. Buck Inc.). The EXPOLIS-Helsinki VOC study samples were collected into Perkin Elmer Tenax TA (Chrompack) adsorbent tubes (Tenax TA tubes) with average sampling volumes of 2.30 L and 2.83 L in personal and microenvironment sampling, respectively (I; Table 1). Target compounds of the EXPOLIS-

Helsinki carbonyl study were sampled using Sep-Pak DNPH-Silica cartridges (Waters Inc.) (DNPH cartridges). In this case, the average sampling volumes were 66.4 L and 122.6 L for personal and microenvironment measurements, respectively. Sampling flow rates were limited by small pore stainless steel (Tenax TA sampling) and Teflon (DNPH sampling) tubes placed in-line between the sampling pump and the sampling tube/cartridge (Figure 5). A diffusive flow of VOCs and carbonyls from the air to the sample tube/cartridge during the non-actively sampled periods was minimized by diffusion barriers made of small pore stainless steel (Tenax TA sampling) and Teflon (DNPH sampling) tubes (I; Table 2). A copper tube with KI coating was used as an ozone scrubber for all DNPH samples (Arnts and Tejda, 1989). The measurement methodologies are presented in detail in I and IV.

To facilitate comparison of concentration levels between EXPOLIS and other international studies, concentration levels of Tenax TA sampling in the EXPOLIS-Helsinki VOC study were presented as $\mu\text{g}/\text{m}^3$. The results of DNPH sampling in the EXPOLIS-Helsinki carbonyl study were presented as ppb as this unit is used most commonly in international studies of carbonyl compounds.

4.3.3. Sample Analyses

Gas chromatograph (GC) (Hewlett-Packard 5890 Series II+) analysis of the Tenax TA samples was performed by VTT Chemical Technology (Espoo, Finland). VOCs were desorbed from the Tenax TA tubes with helium gas into a cold trap. Subsequent flash desorption was followed by split into two non-polar capillary columns (l=50 m, id=0.2 mm and phase thickness=0.5 μm). VOCs were identified from the mass selective detector (MSD) (Hewlett-Packard 5972) total ion chromatogram by a Wiley 275 software library. Masses were computed using response factors from calibration standards applied to flame ionization detector (FID) peaks. The response factors of halogenated compounds were calculated from MSD total ion chromatogram due to their low response in FID. Xylenes and trimethylbenzenes were quantified using the response factor of toluene. The procedures of the Tenax TA analysis are presented in detail in I.

DNPH sample analysis was performed in the University of Kuopio (Kuopio, Finland). Hydrazone derivatives of carbonyl compounds were eluted from DNPH cartridges with acetonitrile (ACN), followed by injection into a high-pressure liquid chromatograph (HPLC)

(Hewlett-Packard 1050) with a Hypersil BDS C18 column coupled with UV detection (Hewlett-Packard). Pure 2,4-dinitrophenylhydrazine (DNPH) derivatives of carbonyls were synthesized separately for standards by reaction with DNPH. A series of standard solutions were prepared in ACN. The procedures of the DNPH sample analysis are presented in detail in IV and V.

4.4. Quality Assurance/Quality Control (I, IV-V)

Carefully planned QA/QC procedures are needed for international multi-center studies like EXPOLIS to ensure accuracy and comparability of observed pollutant levels between participating centers. The QA/QC procedures for the current study are presented in detail in I, IV and V.

Limits of Detection. The limit of detection (LOD) of each target compound was determined using a definition of the analyte concentration giving a signal level (y_{LOD}) equal to the blank signal (y_B) plus three standard deviations (s_B) of the blank (Miller and Miller, 1986):

$$y_{LOD} = y_B + 3 s_B \quad (1)$$

When the FID/UV response was treated as a dependent variable and concentration as an independent variable the intercept from the calibration standard solution was used as an estimate of analytical noise (y_B). The standard error of the regression line was the estimate of the standard deviation of the blank (s_B) and LOD was the x value for $y = y_{LOD}$. The LODs for Tenax TA sampling ranged from 0.7 $\mu\text{g}/\text{m}^3$ with propylbenzene to 5.2 $\mu\text{g}/\text{m}^3$ with hexaldehyde (with an assumed sampling volume of 2.5 L) (I; Table 3). For DNPH sampling the method LODs ranged from 0.09 ppb with 2-hexanone to 0.64 ppb with methyl-ethyl-ketone (with an assumed sampling volume of 100 L) (V; Table 1).

Field Blanks. Careful field and laboratory operating procedures may still result in contamination of samples through handling and chemical reactions. The level of such contamination was assessed in the EXPOLIS by field blanks, which underwent the same sample and analysis procedures as real samples, except that they were not connected to the pump during sampling. Median field blank contamination of the Tenax TA samples (n=74)

was below the LOD for all target compounds in the study. The 95th percentile of field blank contamination was also below the LOD for all target compounds except benzaldehyde ($2.2 \mu\text{g}/\text{m}^3$), a known artifact with Tenax TA as a result of reaction of the sorbent with strong oxidizing agents (Lewis and Gordon, 1996). Mean contamination found in DNPH-cartridge field blanks ($n=4$) ranged from non-detect levels to 5.73 ppb for acetone (V; Table 1). Acetone contamination was found in all DNPH field blanks, which is in agreement with other studies that also reported high acetone contamination levels in blank DNPH cartridges (Reiss et al., 1995, Grosjean et al., 1996). Further, Müller (1997) found that the acetone contamination in the blanks depended on the ACN used for the elution of carbonyls from sampling cartridges.

Field Duplicates. The precision of both Tenax TA and DNPH sampling methods was assessed by field duplicate measurements collected with normal samples. The median relative percent differences (RPDs) between duplicate samples ranged between 2.4-30.3% for Tenax TA PEM duplicates ($n=15$) with an average of 11.4% (I; Table 5). The median RPD for Tenax TA MEM duplicates ($n=51$) ranged between 3.2-54.3% with an average of 11.6%. The mean RPDs for DNPH cartridge duplicate pairs ($n=3$) ranged between 4.8-21.6% with an average of 11.5% (V; Table 1).

PEM-MEM Comparison. The comparability of personal and microenvironment VOC monitors was determined in a 45-hr experiment carried out in an office building in downtown Helsinki. In this comparison, three PEMs and ten MEMs with Tenax TA sampling tubes were run in parallel. The results of comparison showed PEM/MEM concentration ratios close to 1.0 (mean: 0.95, SD 0.28) for most compounds (I; Table 4). The PEM/MEM concentration ratios for benzaldehyde and octylaldehyde deviated more from 1.0 indicating that PEM-MEM comparisons for these compounds should be interpreted with particular caution (or avoided). Overall, the PEMs slightly underestimated concentrations relative to the MEMs. It must be noted, however, that the MEMs ran for a considerably longer period of time and sampled larger sample volumes in this comparison than in the microenvironment monitoring in the EXPOLIS study (5.8 vs. 2.8 L).

4.5. Source Apportionment (III, V)

In addition to information provided on emission and source inventories, the effect of different VOC sources on air quality can be assessed using receptor-modeling techniques. In this procedure, air concentration measurements of different VOCs are carried out in certain locations (“receptors points”) and are used to apportion the contributions of different sources of these concentrations (Gordon, 1980, Henry et al., 1984, Kao and Friedlander, 1995).

One type of multivariate receptor model, principal component analyses (PCA) on ln-transformed VOC concentration data (Henry et al., 1984, Seinfeld and Pandis, 1998), were used to identify non-smoking sources of VOCs in residential outdoor, residential indoor and workplace microenvironments as well as in personal exposure samples of the EXPOLIS-Helsinki study. The source vectors were obtained from the linear recombination of eigenvectors of the compound concentration correlation matrix, which was produced by applying a VARIMAX rotation algorithm. The sizes of the factor score coefficients for each participant from the PCA corresponded to the loadings of the factor (source vector) for each participant. The factors identified in each microenvironment represented linear combinations of VOC concentrations, which identified similar relationships between compounds in samples from all participants. High correlation between compounds in each microenvironment suggests common sources and sinks between the compounds in these environments and similarities of VOC sources identified in different microenvironments were subsequently used to assess main sources of personal exposures for non-ETS exposed participants.

In addition to PCA used for the VOC data of 201 study participants, correlation matrices for each microenvironment were produced for 16 carbonyls detected (value above LOD) in more than 50% of the samples. Furthermore, as an additional step in attributing sources to carbonyl compounds, correlations between VOC factor scores from PCA and ln-transformed carbonyl concentrations for the non-ETS exposed participants/microenvironments common to both studies were determined to inform on potential sources in each microenvironment, and hence the contribution of these sources to personal exposures.

4.6. Data Analyses

Statistical tests and analyses are summarized in Table 6. Statistical analyses in II and III were carried out using SPSS for Windows version 9.0 (SPSS Inc.). Statistical analyses in IV and V were carried out using STATA version 5.0 (Stata Inc.). Treatment of non-detects was handled on an individual compound basis and LODs were computed for each individual compound. Half of the respective LOD for each compound was used in analyses for samples in which the compound was not detected (Hornung and Reed, 1990).

Table 6. *Statistical tests and data analyses.*

Test or analysis used	Publication no.	Purpose of analysis
Wilcoxon W test and Kolmogorov-Smirnov Z test	II	To examine differences between sub-populations and microenvironments.
Principal Component Analysis (Varimax Rotation) ¹	III	To identify main source categories from personal exposure and microenvironment samples.
Linear Regression ¹	IV, V	To study relationships between personal exposure and microenvironment concentrations. To study relationships between PCA factor score values and microenvironment concentrations.
Spearman's Correlation	IV	To study correlations between personal exposure and microenvironment concentrations. To study correlations between compound concentrations in personal exposure and microenvironment samples.
Pearson's Correlation ¹	V	To study correlations between compound concentrations in personal exposure and microenvironment samples. To study correlations between PCA factor scores and microenvironment concentrations.
Multiple Regression ¹	This Thesis	To study relationships between personal exposure and microenvironment concentrations.

¹Ln-transformed data were used for exposure and microenvironment concentrations.

5. RESULTS

5.1. Personal Exposure Concentrations (II, IV-V)

Descriptive statistics of personal exposure concentrations to VOCs and carbonyls sampled in EXPOLIS-Helsinki are presented in Tables 7 and 8. Toluene had the highest geometric mean personal VOC exposure concentration ($16.3 \mu\text{g}/\text{m}^3$) within the population of Helsinki, followed by m&p-xylenes ($8.7 \mu\text{g}/\text{m}^3$), d-limonene ($8.5 \mu\text{g}/\text{m}^3$), hexaldehyde ($6.8 \mu\text{g}/\text{m}^3$) and α -pinene ($6.5 \mu\text{g}/\text{m}^3$). The HAPs incorporated into the CAA (US EPA, 1991) and detected (value above LOD) in more than 50% of the personal exposure samples were toluene, m&p-xylenes, benzene, ethylbenzene, formaldehyde, acetaldehyde, propionaldehyde and methyl-ethyl-ketone. In contrast, hexane, cyclohexane, styrene, naphthalene, phenol, 1-octanol, 2-butoxyethanol, 1-methyl-2-pyrrolidinone and halogenated compounds were VOCs detected (value above LOD) in less than 20% of the personal exposure samples.

26% of the 201 participants in the EXPOLIS-Helsinki VOC study were active smokers and smoked during their 48-hr personal sampling period. In addition, 40% of the participants reported ETS exposure at some time during the 48-hr sampling period. Geometric mean personal exposure concentrations to ETS related compounds benzene, toluene, m&p-xylenes, o-xylene, styrene, ethylbenzene and trimethylbenzenes were 1.2-1.5 times higher ($p < 0.05$) for ETS exposed participants (including smokers) compared to those not exposed (II; Table 4).

Table 7. Summary statistics of personal 48-hr exposure concentrations to compounds sampled in the EXPOLIS-Helsinki VOC study. Only 90th percentile values are presented for compounds detected (value above LOD) in less than 20% of the samples.

EXPOLIS -Helsinki VOC Study						
(n=183) (concentrations in $\mu\text{g}/\text{m}^3$)						
Compound	AM ¹	SD ²	GM ³	50% ⁴	75% ⁵	90% ⁶
Hexane	-	-	-	-	-	6.4
Nonane	8.0	66.7	1.5	1.3	2.2	5.2
Decane	16.5	125.1	3.2	3.0	5.2	13.3
Undecane	14.3	105.0	3.1	2.7	5.1	12.1
Cyclohexane	-	-	-	-	-	3.5
Benzene	3.4	5.4	2.5	2.6	3.7	5.6
Toluene	25.3	48.2	16.3	13.2	23.2	41.7
Ethylbenzene	7.7	47.0	2.8	2.4	4.0	6.5
m&p-Xylenes	25.0	145.7	8.7	7.3	12.3	18.1
o-Xylene	10.1	65.2	2.8	2.3	4.0	6.4
Styrene	-	-	-	-	-	2.1
Naphtalene	-	-	-	-	-	0.8
Propylbenzene	1.5	3.8	0.74	0.44	1.3	2.6
Trimethylbenzenes	9.0	25.7	3.7	2.9	6.1	14.6
2-Methyl-1-propanol	4.2	6.5	2.1	0.95	5.9	9.6
1-Butanol	7.7	11.4	4.7	5.0	8.3	15.2
2-Ethylhexanol	3.4	3.0	2.6	2.2	4.1	6.5
Phenol	-	-	-	-	-	2.3
1-Octanol ⁷	-	-	-	-	-	-
2-Buthoxyethanol	-	-	-	-	-	3.6
Hexaldehyde	8.2	7.5	6.8	6.7	9.5	14.1
Benzaldehyde	4.7	2.3	3.8	4.6	5.7	7.3
Octylaldehyde	4.4	2.6	3.8	4.1	5.5	7.0
Trichloroethene	-	-	-	-	-	1.2
Tetrachloroethene	-	-	-	-	-	1.1
1,1,2-Trichloroethane ⁷	-	-	-	-	-	-
d-Limonene	18.7	30.1	8.5	7.7	19.1	44.3
1-Methyl-2-pyrrolidinone	-	-	-	-	-	2.9
3-Carene	3.3	5.4	1.7	1.9	3.7	7.2
α -Pinene	10.2	14.0	6.5	6.4	10.3	22.8

¹Arithmetic mean.

²Standard deviation.

³Geometric mean.

⁴50th percentile.

⁵75th percentile.

⁶90th percentile.

⁷Not found above LOD in any of the samples.

Table 8. Summary statistics of personal 48-hr exposure concentrations to compounds sampled in the EXPOLIS-Helsinki carbonyl study. Only 90th percentile values are presented for compounds detected (value above LOD) in less than 50% of the samples.

EXPOLIS -Helsinki Carbonyl Study						
(n=15) (concentrations in ppb)						
Compound	AM ¹	SD ²	GM ³	50% ⁴	75% ⁵	90% ⁶
Formaldehyde	21.4	11.1	18.7	18.0	29.1	37.5
Acetaldehyde	7.9	3.9	6.8	7.1	10.5	13.5
Acetone	23.6	48.3	8.8	12.1	16.1	22.0
Propionaldehyde	0.74	0.30	0.64	0.85	0.93	1.0
Methy-ethyl-ketone	0.89	0.73	0.66	0.69	1.2	2.0
Butyraldehyde	0.68	0.40	0.55	0.69	1.0	1.2
2-Pentanone	-	-	-	-	-	2.7
Valeraldehyde	0.90	0.53	0.67	1.0	1.2	1.3
3-Methyl-2-pentanone	-	-	-	-	-	0.22
2-Hexanone	-	-	-	-	-	0.05
Heptylaldehyde	0.33	0.27	0.19	0.29	0.57	0.66
Nonylaldehyde	1.4	0.42	1.3	1.5	1.6	1.9
Decylaldehyde	1.2	0.28	1.2	1.2	1.4	1.6

¹Arithmetic mean.

²Standard deviation.

³Geometric mean.

⁴50th percentile.

⁵75th percentile.

⁶90th percentile.

Comparison of smokers with non-smokers was not carried out in the EXPOLIS-Helsinki carbonyl study as the numbers of smokers and microenvironments where smoking occurred indoors were small, which precluded meaningful comparison. However, the highest single exposure concentrations were typically observed for non-smoking participants of the study.

The compound with the highest geometric mean personal exposure concentration found in the carbonyl study was formaldehyde (18.7 ppb), next in rank came acetone (8.8 ppb), acetaldehyde (6.8 ppb) and nonylaldehyde (1.3 ppb). Overall, all carbonyls except 2-pentanone, 3-methyl-pentanone and 2-hexanone, were detected (value above LOD) in more than 50% of the personal exposure samples of the study.

5.2. Relationships between Personal Exposure and Microenvironment Concentrations (II, IV-V)

5.2.1. Residential Outdoor Environments

In the residential outdoor environment, more than half of the target compounds in the VOC study were detected (value above LOD) in less than 20% of the samples (n=156). Toluene had the highest geometric mean residential outdoor concentration ($3.7 \mu\text{g}/\text{m}^3$) in the VOC study, followed by m&p-xylenes ($2.4 \mu\text{g}/\text{m}^3$), benzaldehyde ($2.1 \mu\text{g}/\text{m}^3$), hexaldehyde ($2.0 \mu\text{g}/\text{m}^3$), octylaldehyde ($1.5 \mu\text{g}/\text{m}^3$) and α -pinene ($1.5 \mu\text{g}/\text{m}^3$) (II; Table 1). Geometric mean concentrations of other BTEX-compounds, benzene, o-xylene and ethylbenzene were 1.4, 1.1 and $0.8 \mu\text{g}/\text{m}^3$, respectively. Although residential outdoor environments were monitored mostly during evenings and nights, typical traffic related VOCs were the most prevalent compounds in these environments. In a further analysis of outdoor concentrations, significantly ($p < 0.05$) elevated levels of m&p-xylenes, ethylbenzene, toluene and nonane were observed outside residences where participants reported continuous compared to very infrequent traffic or heavy traffic volumes (II; Table 3).

In the carbonyl study, three out of the 16 target compounds were detected (value above LOD) in less than 20% of the residential outdoor samples (n=13). Formaldehyde and acetaldehyde were the carbonyl study compounds with the highest geometric mean residential outdoor concentrations, 1.6 and 1.1 ppb, respectively. Two other carbonyls classified as HAPs, methyl-ethyl-ketone and propionaldehyde, were detected (value above LOD) in 0 and 23% of the outdoor samples, respectively. Overall, geometric mean outdoor concentrations were below 1.0 ppb for all compounds except formaldehyde and acetaldehyde (V; Table 2).

Table 9 presents the 25th, 50th and 75th percentile values of I/O-, P/I- and P/O-ratios for non-ETS exposed environments/participants of the EXPOLIS-Helsinki VOC study. Table 10 presents the 25th, 50th and 75th percentile values of I/O-, P/I- and P/O-ratios for participants of the EXPOLIS-Helsinki carbonyl study.

Table 9. Summary of 25th, 50th and 75th percentile values of I/O-, P/I- and P/O-ratios in the EXPOLIS-Helsinki VOC study (non-ETS exposed). Only compounds and values detected (value above LOD) in more than 20% of the personal exposure or indoor air samples are included.

Compound	I/O-ratio (n=140)			P/I-ratio (n=106)			P/O-ratio (n=89)		
	25% ¹	50% ²	75% ³	25% ¹	50% ²	75% ³	25% ¹	50% ²	75% ³
Alkanes									
Nonane	1.0	1.5	3.3	0.7	1.0	1.4	1.2	1.6	3.4
Decane	1.3 ⁴	3.0 ⁴	6.3 ⁴	0.7	1.0	1.5	1.6 ⁴	3.2 ⁴	7.7 ⁴
Undecane	2.6 ⁴	5.1 ⁴	10.0 ⁴	0.8	1.0	1.7	3.5 ⁴	5.7 ⁴	9.0 ⁴
Aromatics									
Benzene	0.6	1.1	1.4	1.0	1.3	2.5	1.0	1.4	2.2
Toluene	1.9	3.4	6.5	0.8	1.0	1.3	2.4	3.7	6.0
Ethylbenzene	1.4 ⁴	2.3 ⁴	4.0 ⁴	0.9	1.1	1.7	1.8 ⁴	3.3 ⁴	4.5 ⁴
m&p-Xylenes	1.4	2.2	3.4	0.9	1.2	1.7	1.9	3.3	4.4
o-Xylene	1.1 ⁴	1.4 ⁴	2.4 ⁴	1.0	1.3	2.0	1.4 ⁴	2.2 ⁴	3.4 ⁴
Styrene	0.9 ^{4,5}	1.2 ^{4,5}	1.9 ^{4,5}	-	-	-	-	-	-
Propylbenzene	0.9 ⁴	1.1 ⁴	2.1 ⁴	0.9	1.3	1.7	1.3 ⁴	1.6 ⁴	2.5 ⁴
Trimethylbenzenes	1.0 ⁴	1.7 ⁴	3.1 ⁴	0.9	1.3	1.7	1.5 ⁴	2.5 ⁴	4.7 ⁴
Alcohols									
2-Methyl-1-propanol	1.1 ⁴	6.5 ⁴	14.2 ⁴	0.3	0.7	1.1	1.3 ⁴	1.7 ⁴	9.7 ⁴
1-Butanol	5.8 ⁴	12.1 ⁴	23.3 ⁴	0.5	0.7	0.9	4.7 ⁴	8.4 ⁴	14.8 ⁴
2-Ethyl-1-hexanol	1.0 ⁴	1.4 ⁴	3.7 ⁴	0.8	1.0	1.4	1.4 ⁴	1.8 ⁴	3.2 ⁴
Esters									
2-Buthoxyethanol	0.9 ^{4,5}	1.1 ^{4,5}	1.3 ^{4,5}	-	-	-	-	-	-
Aldehydes									
Hexaldehyde	2.7 ⁴	4.5 ⁴	7.9 ⁴	0.6	0.7	1.0	2.2 ⁴	3.6 ⁴	5.4 ⁴
Benzaldehyde	1.2	1.8	2.7	0.7	1.0	1.2	1.3	1.7	2.2
Octylaldehyde	1.6 ⁴	2.5 ⁴	3.9 ⁴	0.9	1.0	1.3	1.7 ⁴	2.6 ⁴	3.8 ⁴
Terpenes									
d-Limonene	5.9 ⁴	17.1 ⁴	39.2 ⁴	0.6	0.8	1.0	5.0 ⁴	12.7 ⁴	37.6 ⁴
3-Carene	1.3 ⁴	7.7 ⁴	19.0 ⁴	0.5	0.7	1.2	1.6 ⁴	5.2 ⁴	10.6 ⁴
α-Pinene	3.1 ⁴	6.2 ⁴	13.2 ⁴	0.6	0.7	0.9	2.5 ⁴	5.0 ⁴	8.0 ⁴

¹25th percentile.

²50th percentile.

³75th percentile.

⁴Low detection in residential outdoor air: found above LOD in less than 30% of the samples.

⁵Low detection in residential indoor air: found above LOD in less than 30% of the samples.

Table 10. Summary of 25th, 50th and 75th percentile values of I/O-, P/I- and P/O-ratios in the EXPOLIS-Helsinki carbonyl study. Only compounds and values detected (value above LOD) in more than 20% of the personal exposure or indoor air samples are included.

Compound	I/O-ratio (n=13)			P/I-ratio (n=15)			P/O-ratio (n=13)		
	25% ¹	50% ²	75% ³	25% ¹	50% ²	75% ³	25% ¹	50% ²	75% ³
Formaldehyde	13.2	25.7	39.6	0.6	0.7	0.8	2.9	17.5	26.9
Acetaldehyde	5.9	10.9	19.5	0.7	0.7	0.8	3.8	7.0	13.6
Acetone	7.2	78.3	307	0.6	0.7	1.1	6.3	54.2	145
Propionaldehyde	8.7 ⁴	10.0 ⁴	11.7 ⁴	0.6	0.8	1.1	4.5 ⁴	8.1 ⁴	11.6 ⁴
Methyl-ethyl-ketone	1.0 ⁴	1.9 ⁴	2.7 ⁴	1.0	1.0	1.8	1.0 ⁴	2.2 ⁴	3.4 ⁴
Butyraldehyde	1.3	2.2	4.2	0.8	1.0	1.2	1.2	2.9	4.9
Valeraldehyde	2.2	3.4	11.1	0.5	0.7	0.9	1.7	2.7	10.3
3-Methyl-2-pentanone	1.0 ⁴	1.0 ⁴	1.7 ⁴	-	-	-	-	-	-
2-Hexanone	1.0 ^{4,5}	1.0 ^{4,5}	4.2 ^{4,5}	-	-	-	-	-	-
Heptylaldehyde	3.4	7.6	12.6	0.3	0.9	1.2	1.0	4.4	9.3
Nonylaldehyde	3.4	5.0	7.5	0.5	0.7	0.8	2.8	3.2	4.3
Decylaldehyde	2.0	2.9	3.8	0.9	1.1	1.4	2.3	2.7	3.1

¹25th percentile.

²50th percentile.

³75th percentile.

⁴Low detection in residential outdoor air: found above LOD in less than 30% of the samples.

⁵Low detection in residential indoor air: found above LOD in less than 30% of the samples.

Median P/O-ratios exceeded 1.4 for all compounds except benzene. In addition, for 23 compounds the median P/O-ratio was higher than 2.0 and for 10 compounds higher than 4.0. Twenty-fifth percentile values of the P/O-ratio were not smaller than 1.0 for any compound in the study.

5.2.2. Residential Indoor Environments

In residential indoor environments, nine out of the 30 target compounds in the EXPOLIS-Helsinki VOC study were detected (value above LOD) in less than 20% of the samples (n=181). Toluene had the highest geometric mean residential indoor concentration (14.6 $\mu\text{g}/\text{m}^3$), followed by d-limonene (11.6 $\mu\text{g}/\text{m}^3$), α -pinene (9.1 $\mu\text{g}/\text{m}^3$), hexaldehyde (8.7 $\mu\text{g}/\text{m}^3$) and 1-butanol (7.0 $\mu\text{g}/\text{m}^3$) (II; Table 1). Geometric means for other BTEX-compounds, benzene, ethylbenzene, m&p-xylenes and o-xylene were 1.6, 2.2, 6.1 and 1.9 $\mu\text{g}/\text{m}^3$, respectively.

In the carbonyl study, three compounds, methyl-ethyl-ketone, 2-pentanone and 2-hexanone, were detected (value above LOD) in less than 50% of the samples (n=15). Formaldehyde was the carbonyl with the highest geometric mean residential indoor concentration (28.3 ppb), followed by acetone (14.6 ppb), acetaldehyde (8.8 ppb) and nonylaldehyde (2.1 ppb) (V; Table 2).

Maximum concentrations of VOCs were systematically an order of magnitude above geometric mean concentrations in residences. For 13 of the compounds shown in Tables 9 and 10 (two alcohols, all three terpenes and eight carbonyls), the median P/I-ratio was smaller than 1.0, indicating the importance of the residential indoor environment as a source of personal exposure to these compounds. This was explained by the fact that study participants spent, on average, 60% of their daily time in residences (Jantunen et al., 1999). For aromatic compounds the median P/I-ratio was systematically higher than 1.0 (1.0-1.3) indicating that personal activities, such as commuting and occupational exposure, played a role in exposure to these compounds. Decylaldehyde was the only carbonyl with the median P/I-ratio higher than 1.0.

The median I/O-ratio was equal or higher than 1.0 for all target compounds shown in Tables 9 and 10. Compounds with the median I/O-ratios ranging between 1.0-4.0 were all aromatics, two alkanes (nonane and decane), 2-ethyl-1-hexanol and half of the carbonyls. Compounds with the median I/O-ratios higher than 4.0 were undecane, 2-methyl-1-propanol, 1-butanol, all terpenes and the remaining half of the carbonyls. Overall, I/O-ratios indicated indoor sources for a great majority of target compounds in EXPOLIS-Helsinki as direct emissions or indoor chemical formation.

5.2.3. Workplace Environments

In the EXPOLIS-Helsinki VOC study, around half of the target compounds were detected (value above LOD) in more than 20% of the workplace samples (n=140). Toluene had the highest geometric mean workplace concentration (9.5 $\mu\text{g}/\text{m}^3$), followed by m&p-xylenes (7.0 $\mu\text{g}/\text{m}^3$), hexaldehyde (4.2 $\mu\text{g}/\text{m}^3$), benzaldehyde (4.0 $\mu\text{g}/\text{m}^3$) and d-limonene (3.4 $\mu\text{g}/\text{m}^3$). Maximum levels for alkanes, aromatics and halogenated compounds in the workplace microenvironments were higher than residential indoor maximum levels of these compounds, although VOCs were generally detected less frequently and at lower concentrations in

workplaces. Significantly ($p < 0.05$) elevated levels of m&p-xylenes, o-xylene, toluene, ethylbenzene, propylbenzene, trimethylbenzenes and hexane were observed in ETS-free workplaces where participants reported continuous compared to very infrequent traffic or heavy traffic volume in the streets outside the workplace (II; Table 3).

Seven target compounds of the carbonyl study were detected (value above LOD) in less than 50% of the workplace samples ($n=9$). As in residential indoor samples, acetone, propionaldehyde, valeraldehyde, nonylaldehyde and decylaldehyde were found systematically in workplace environments, but with lower geometric mean concentrations. In addition, methyl-ethyl-ketone, butyraldehyde, benzaldehyde and 2-hexanone were more prevalent and had higher geometric mean concentrations in residences compared to workplace environments. Formaldehyde was the carbonyl compound with the highest geometric mean workplace concentration (11.0 ppb), followed by acetone (4.0 ppb), acetaldehyde (2.2 ppb) and nonylaldehyde (1.0 ppb) (V; Table 2).

5.2.4. Summary of Relationships

Multivariate regression models using residential outdoor, residential indoor and workplace VOC concentrations were used to give additional information about the roles of these microenvironmental concentrations as well as of other possible sources (e.g., transport and commuting) to account for the variation in personal VOC exposure concentrations of non-ETS exposed participants (Table 11). The model accounted for 39% (benzene) to 77% (α -pinene) of the personal exposure variance and confirmed the minor role of residential outdoor concentrations as a determinant of personal exposure to VOCs in Helsinki. Benzaldehyde was the only compound, which showed statistically significant ($p < 0.05$) associations between residential outdoor and personal exposure concentrations. Residential indoor and workplace concentrations were the strongest predictors of the variance in personal VOC exposure concentrations in the regression analysis – residential indoor concentration showed statistically significant ($p < 0.05$) associations with all and workplace concentration with 13 out of the 19 VOCs included in the analysis. In addition, the “intercept” term in the linear regressions showed statistically significant ($p < 0.05$) associations with the variance in personal exposure concentrations to all BTEX-compounds as well as to 2-ethyl-1-hexanol, hexaldehyde, octylaldehyde and α -pinene. This indicated that personal activities such as e.g.,

transport and commuting, had an effect on personal exposure concentrations to these compounds.

Residential indoor carbonyl concentrations were the strongest predictors of the variance in personal exposure concentrations in the simple regression analysis and explained more than 50% of the variance in acetone, hexaldehyde and nonylaldehyde exposures (V; Table 4). Propionaldehyde was the only compound for which workplace concentrations accounted for more than 50% of the variance in personal exposure concentrations. Residential outdoor concentrations were weak estimators of the variance in personal exposure levels, with the highest proportion observed for valeraldehyde and nonylaldehyde (for both c.a. 20%).

Table 11. Results of multivariate regression using residential outdoor, residential indoor and workplace air concentrations to predict personal exposure concentrations of non-ETS exposed participants of the EXPOLIS-Helsinki VOC study (n=65). Only compounds detected (value above LOD) in more than 30% of the personal exposure samples are included. p-Values smaller than 0.05 are marked with bold. For analysis, data were ln-transformed.

Compound	Residential Out			Residential In			Workplace			Intercept			Model
	Coeff. ¹	Std. Err. ²	p-value	Coeff. ¹	Std. Err. ²	p-value	Coeff. ¹	Std. Err. ²	p-value	Coeff. ¹	Std. Err. ²	p-value	R ² -value
Nonane	0.02	0.098	0.828	0.45	0.073	0.000	0.50	0.062	0.000	0.03	0.788	0.687	0.65
Decane	0.07	0.137	0.618	0.57	0.071	0.000	0.43	0.063	0.000	0.18	0.116	0.121	0.64
Undecane	-0.04	0.128	0.758	0.58	0.068	0.000	0.44	0.067	0.000	0.18	0.148	0.215	0.65
Benzene	0.25	0.155	0.113	0.25	0.099	0.015	0.27	0.116	0.021	0.33	0.104	0.003	0.39
Toluene	0.13	0.084	0.139	0.44	0.085	0.000	0.27	0.076	0.001	0.71	0.239	0.004	0.51
Ethylbenzene	0.13	0.095	0.178	0.34	0.069	0.000	0.28	0.057	0.000	0.44	0.080	0.000	0.52
m&p-Xylenes	0.08	0.069	0.261	0.49	0.071	0.000	0.27	0.055	0.000	0.53	0.149	0.001	0.61
o-Xylene	0.08	0.093	0.391	0.46	0.072	0.000	0.29	0.061	0.000	0.34	0.071	0.000	0.57
Propylbenzene	0.08	0.151	0.611	0.42	0.082	0.000	0.54	0.074	0.000	0.14	0.195	0.460	0.52
Trimethylbenzenes	-0.05	0.100	0.602	0.57	0.078	0.000	0.48	0.060	0.000	0.17	0.102	0.106	0.64
2-Methyl-1-propanol	-0.09	0.355	0.807	0.43	0.085	0.000	0.47	0.126	0.000	0.04	0.240	0.869	0.40
1-Butanol	0.06	0.155	0.699	0.60	0.074	0.000	0.15	0.085	0.094	0.34	0.197	0.092	0.55
2-Ethyl-1-hexanol	-0.11	0.119	0.359	0.56	0.057	0.000	0.14	0.081	0.096	0.31	0.091	0.001	0.66
Hexaldehyde	-0.05	0.099	0.618	0.50	0.058	0.000	0.27	0.081	0.001	0.45	0.173	0.011	0.61
Benzaldehyde	0.23	0.098	0.020	0.33	0.113	0.005	0.36	0.104	0.001	0.15	0.186	0.420	0.49
Octylaldehyde	-0.15	0.093	0.120	0.63	0.073	0.000	0.14	0.094	0.155	0.44	0.113	0.000	0.61
d-Limonene	-0.12	0.177	0.493	0.71	0.068	0.000	0.06	0.066	0.352	0.32	0.187	0.091	0.70
3-Carene	-0.09	0.158	0.370	0.69	0.065	0.000	0.07	0.092	0.469	-0.11	0.186	0.543	0.68
α-Pinene	-0.07	0.098	0.481	0.67	0.053	0.000	0.10	0.061	0.117	0.34	0.133	0.014	0.77

¹Coefficient.

²Standard error.

5.3. Source Apportionment (III, V)

Residential Outdoor Environments. PCA of the variability in residential outdoor concentrations were dominated by four factors that together accounted for 79% of the total variance between concentrations (III; Table 7). The strongest factor accounted alone for 33% of the variance and was highly correlated with BTEX-compounds, hexane and trimethylbenzenes (III; Table 2). The strongest and the second strongest factors (factor 1 and 2) together accounted for 53% of the variance between outdoor concentrations. Factor 2 correlated strongly with three volatile alkanes (decane, nonane and undecane) and in lesser extent with ethylbenzene and trimethylbenzenes.

The VOCs associated with factors 1 and 2 were typical for motor vehicle (both gasoline and diesel powered) emissions (Chan et al., 1991a, Chan et al., 1991b, Weisel et al., 1992, Wixtrom and Brown, 1992, Barrefors and Petersson, 1992, Lawryk et al., 1995, Ilgen et al., 2001a, Watson et al., 2001). However, as the more volatile compounds of traffic emissions were strongly present in factor 2 it was concluded that this factor represented more recent local Helsinki metropolitan area traffic emissions (III; Table 7). Factor 1 represented more long-range transport (from sources outside Helsinki) of motor vehicle and other combustion related VOC pollutants. This conclusion was strongly supported by the fact that factor 1 was highly dependent on wind direction (III; Figure 1) having main sources lying to the east of Helsinki. Such long-range transport of motor vehicle and other combustion related VOC pollutants might originate from traffic emissions in the St. Petersburg area of Russia (350 km away from Helsinki) and VOC emissions from the Fortum oil refinery in Porvoo (30 km away from Helsinki) as both of these lie to the east from Helsinki. Further wind vector analysis would be required to directly identify the origins of these sources, but was not part of data collected in the EXPOLIS study.

Factor 3 accounted for 16% of the variance in residential outdoor concentrations and was identified as emissions from trees as α -pinene is one of the main compounds in these emissions (Helmig and Arey, 1992, Colls, 1997, Mølhave et al., 2000). Furthermore, factor 4 accounted for 10% of the variance and had strong association with benzaldehyde. This factor was identified as emissions from seasonal oxidation products, supported by the high variation in residential outdoor concentrations of benzaldehyde during different seasons (III; Figure 2).

Typical traffic related carbonyls, formaldehyde and acetaldehyde (Baugh et al., 1987, Calvert and Madronich, 1987, Granby et al., 1997), showed high correlation between each other as well as with nonylaldehyde in residential outdoor environments (V; Table 5) and were reflected in the association with the VOC factor identified as seasonal oxidation products (V; Table 6). This indicated, overall, low primary traffic emissions of these compounds during the evening and nighttime in Helsinki. Decylaldehyde showed no association with other carbonyls in the outdoor environment but was the only compound associated with VOC factor identified as emissions from trees and vegetation. There have been studies that have indicated decylaldehyde emissions from woody species (Ciccioli et al., 1999, Peneuelas and Liusia, 2001).

Residential Indoor Environments. The variability in ETS-free residential indoor VOC concentrations was dominated by six factors that together accounted for 73% of the total variance between indoor concentrations. The two strongest factors each separately accounted for 18% of the variance (III; Table 7). Four other factors accounted for 17%, 9%, 6% and 6% of the variance, respectively.

Factor 1 correlated highly with the VOC study compounds α -pinene, 3-carene and hexaldehyde and to a lesser degree with 1-butanol, 2-methyl-1-propanol, octylaldehyde and d-limonene (III; Table 3). All of these compounds, except octylaldehyde (2.5), had a median I/O-ratio higher than 4.0 (Table 9). This factor was identified as emissions from indoor sources such as cleaning products, fragrances, consumer products, particleboard etc. Many previous studies support this identification (Knöppel and Schauenburg, 1989, Wallace, 1991, Fellin and Otson, 1994, Cooper et al., 1995, Wallace, 1996b, Hodgson et al., 2000).

Factor 2 in the residential indoor air analysis correlated highly with volatile alkanes (decane, nonane and undecane) and trimethylbenzenes (similar to factor 2 in the residential outdoor air analysis), and was identified as local traffic emissions. Factor 3 was highly correlated with BTEX-compounds and trimethylbenzenes similar to factor 1 in the residential outdoor air analysis and was also identified as motor vehicle and other combustion related outdoor VOCs. It must be noted, however, that the concentrations of these compounds associated with traffic emissions were generally higher in residential indoor than residential outdoor microenvironments (Table 9, III; Table 6) indicating additional indoor sources for these compounds in Helsinki, in agreement with many previous studies (Wadden et al., 1986,

Brown et al., 1994, Fellin and Otson, 1994, Brown and Crump, 1996, Hoffman et al., 2000, Ilgen et al., 2001a).

Factor 4 in the residential indoor air analysis correlated with 1-butanol, 2-ethyl-1-hexanol, benzaldehyde and octylaldehyde in the VOC study and was identified as residential product emissions (e.g., plastics, paints), as was factor 5 which was associated with styrene (previously identified from carpets, rubber and adhesives) (Wolkoff, 1995).

Strong inter-compound correlations between most of the carbonyl study compounds in residential indoor concentrations (V; Table 5) suggested common indoor sources for these compounds. The carbonyls with the strongest associations (e.g., acetone, butyraldehyde, valeraldehyde and heptylaldehyde) were significantly correlated with the VOC factor associated with cleaning products, fragrances, consumer products and particle board (V; Table 6) and had median I/O-ratios of at least 2.2 indicating the important role of residential indoor sources for these compounds (Table 10).

VOC factor 2, associated with traffic emissions, was weakly associated in the carbonyl study with propionaldehyde. While this carbonyl is typically associated with anthropogenic sources and traffic emissions in ambient air (Shepson et al., 1991), here the detection frequency and concentrations of the compound were higher in the indoor environment indicating considerable indoor sources introducing variability in these associations (Table 10).

VOC factor 4, associated with building and product emissions, showed correlation with acetaldehyde and was also associated with formaldehyde. Median I/O-ratios of formaldehyde and acetaldehyde were 25.7 and 10.9 (Table 10), respectively, indicating remarkable indoor sources for these carbonyls. According to the literature, indoor sources of formaldehyde include cigarette smoke, insulating materials, chipboard or plywood furniture, water-based paints, fabrics, household cleaning agents, disinfectants, particle board and other construction materials. Indoor acetaldehyde concentrations in residences have been related to emissions from smoking and combustion appliances, cosmetic products and some hobby supplies as photographic chemicals and special adhesives (Maroni et al., 1995, Humfrey et al., 1996).

Workplace Environments. VOC concentrations at workplaces were measured mostly during the daytime. In addition, the workplaces were mostly office type buildings located in areas with high traffic densities. For this reason it was not very surprising that the strongest

factor (accounted 24% of the variance) in ETS-free indoor workplace microenvironments correlated highly with decane, nonane, undecane and trimethylbenzenes as well as in lesser degree with ethylbenzene and xylenes indicating local traffic emissions as a main source for this factor (III; Tables 4 and 7). Factor 2 accounted for 21% of the variation in workplace concentrations, correlated especially with 3-carene, α -pinene, hexaldehyde and 1-butanol, and was identified as emissions from cleaning and other indoor products (similar to residential indoor factors 1 and 4). Factor 3 in workplaces accounted for 19% of the concentration variance and correlated highly with BTEX-compounds and hexane, similar to factor 1 in residential outdoor samples representing long-range transport of motor vehicle and other combustion related VOCs. Factor 4 correlated mainly with d-limonene, which has been previously identified with air fresheners, perfumes, colognes, soaps and other cleaning products (Cooper et al., 1995).

Local traffic emissions also played an important role for carbonyl concentrations in workplaces (V; Table 6). It must be noted again, however, that geometric means of measured compounds were systematically higher in workplaces and residential indoor environments when compared to residential outdoor environments and thus indoor sources played significant role in both of these indoor microenvironments. Acetaldehyde, acetone, heptylaldehyde and octylaldehyde were associated in workplaces with product emissions similar to associations found in residential indoor environments. In addition, acetaldehyde showed associations with outdoor traffic and combustion emissions, as did heptylaldehyde and nonylaldehyde, but to a lesser degree. These associations supported both indoor and outdoor sources for acetaldehyde and heptylaldehyde in workplaces. The VOC factor associated with air fresheners and elevated d-limonene concentrations in the workplace environment correlated negatively with carbonyls such as formaldehyde, acetaldehyde, benzaldehyde and heptylaldehyde.

Personal Exposure Samples. The VOC factor 1 in 48-hr personal exposure concentrations of non-ETS exposed participants of EXPOLIS-Helsinki accounted for 19% of the exposure variance (III; Table 7) and correlated strongly with nonane, decane, undecane, trimethylbenzenes and propylbenzene as well as with ethylbenzene and xylenes, but to a lesser degree (III; Table 5). Factor 2 accounted for 17% of the exposure variance and correlated mainly with o-xylene, ethylbenzene, m&p-xylenes, styrene and toluene. Both of these factors mainly reflected traffic related outdoor sources. Factor 3 accounted for 12% of the variance, correlated with 3-carene, α -pinene and hexaldehyde, and was identified as

emissions from household cleaning products and personal toiletries (Knöppel and Schauenburg, 1989, Cooper et al., 1995). Factor 4 which accounted for 10% of the variance correlated most strongly with 2-ethylhexanol, benzaldehyde, octylaldehyde and 1-butanol (in a manner similar to factor 4 in residential indoor concentrations) and was identified as a variety of personal and indoor product emissions. Factor 5 correlated with benzene and hexane and indicated that these two compounds would have their own factor identified with outdoor traffic and combustion pollution reflecting the associations of these compounds in workplace and outdoor microenvironments but not in residential indoor microenvironments.

In personal carbonyl exposure concentrations, acetone and propionaldehyde showed strong correlation (V; Table 5) between each other and were associated with the VOC factor for product emissions as well as formaldehyde, acetaldehyde, valeraldehyde and heptylaldehyde (V; Table 6). All of these compounds except propionaldehyde were associated with cleaning and building product emissions in the residential indoor environment. Formaldehyde, acetaldehyde, acetone and valeraldehyde also showed correlations with the factor identified as local traffic emissions in personal samples. Overall, although in PCA the VOCs were similar in local and long range traffic emissions (factors 1 and 2, respectively), due to similar combustion processes for traffic emissions, different carbonyl compounds were correlated with these factors supporting the idea that these sources were distinct.

Methyl-ethyl-ketone was detected (value above LOD) in more than 50% of the measurements only in personal samples. It seemed plausible that some specific personal activities determined personal exposure concentrations to this compound, which showed some correlation with the VOC factor identified to emissions from cleaning products (V; Table 6).

6. DISCUSSION

6.1. Personal Exposure Concentrations

Daytime geometric mean personal exposure concentrations to benzene varied in the Los Angeles TEAM study for the sub-populations of smokers, ETS exposed (including smokers) and non-ETS exposed participants in 21.3, 16.6 and 9.2 $\mu\text{g}/\text{m}^3$, respectively (Hartwell et al., 1992). In addition, the personal exposure concentrations of three other smoking related VOCs, ethylbenzene, m&p-xylenes and octane, were 1.4-2.0 times higher for the population of ETS exposed participants (including smokers) than for those not exposed. In Europe, the mean personal exposure concentrations of benzene have been 1.7-2.4 times higher for the population of smokers when compared to non-smokers (Hoffmann et al., 1996). Furthermore, in the European GerES II study, the most important determinant of non-smoking population's benzene exposure was the presence of ETS indoors (Hoffmann et al., 2000).

In EXPOLIS-Helsinki, geometric mean exposure concentrations to benzene, toluene, styrene, ethylbenzene, trimethylbenzenes, m&p-xylenes and o-xylene were 1.2-1.5 times higher for the ETS exposed Helsinki population (including smokers) than for those not exposed. Arithmetic mean personal exposure concentrations to benzene were 5.1 and 2.6 $\mu\text{g}/\text{m}^3$ for the populations of active smokers and non-smokers, respectively (Edwards and Jantunen, 2001). Overall, the significance of tobacco smoke as a source of VOC exposure in Helsinki was demonstrated clearly in the current study. However, it is important to note that in EXPOLIS, for those participants that actively smoked, personal exposures reflected concentrations of VOCs in the air around the participant and not the dose received from actively inhaling smoke directly from a cigarette.

Personal exposure concentrations to benzene were lower in the population of Helsinki compared to other studies carried out both in North America and Western Europe (Ullrich et al., 1996, Wallace et al., 1996, Hoffman et al., 2000, Cocheo et al., 2000, Ilgen et al., 2001b). Toluene had the highest geometric mean personal exposure concentration within the population of Helsinki, followed by m&p-xylenes, benzaldehyde, hexaldehyde and α -pinene. Overall, geometric mean personal exposure concentrations to VOCs on a population basis were systematically much lower in Helsinki than in Germany (GerES II) with the exception of two alcohols (2-methyl-1-propanol and 1-butanol) and hexaldehyde, which all had higher geometric mean concentrations in Helsinki. In addition, the highest exposure concentrations

observed in Helsinki were generally lower or of similar magnitude to the highest levels in Germany, with the exception of hexaldehyde and indoor related terpenes (α -pinene, d-limonene and 3-carene), which are typical compounds used in cleaning products, soaps and air fresheners (Knöppel and Schauenburg, 1989, Cooper et al., 1995). Extreme exposure levels found in Helsinki were commonly explained by abnormal conditions such as smoking, high occupational exposures or renovations and building modifications performed at the participant's residence. Clearly, quite focused measures could reduce these exposures. Differences in behavior or choice of consumer products between Germany and Finland were indicated in the current study as the geometric mean personal exposure concentrations to α -pinene were similar, but geometric mean exposure concentrations to 3-carene and d-limonene were 2-4 times higher in the GerES II study when compared to EXPOLIS-Helsinki. This suggested that more general class products containing d-limonene and 3-carene as well as air fresheners, detergents and fragrances were used in western German homes. In contrast, similar use of α -pinene containing waxes, polishes and perfumes appeared to occur. Overall, the role of these sources in personal exposure of the Helsinki population was important but not so dramatically as in the TEAM study where the major source of human exposure to toxic and carcinogenic VOCs (e.g., p-dichlorobenzene) of the non-smoking US population was assessed to be room air fresheners and household and bathroom deodorizers (Wallace, 1996b).

Further comparison with the TEAM study indicated that median personal exposure concentrations were considerably higher (usually by a factor of 2 or more) in all the TEAM locations compared to the current study for benzene, ethylbenzene, m&p-xylenes, o-xylene and styrene (Wallace et al., 1996). Median exposure concentrations to halogenated compounds and the frequency of detection in personal exposure samples were higher in the TEAM study compared to the GerES II and the EXPOLIS-Helsinki samples. This can be explained by the relative high concentrations of these compounds found in many household products (automotive products, household cleaners/polishes, paints, fabric and leather treatments and dry cleaning chemicals) used commonly in North America (Sack et al., 1992, Daisey et al., 1994). In addition, halogenated compounds were detected far more commonly in personal exposure samples in Germany than in Helsinki. Overall, these findings indicate the minor role of these compounds in personal exposures of the Helsinki population as well as differences in products or the frequency of product use between Finland and Germany as well as between Europe and North America.

Personal exposure concentrations to formaldehyde indicated higher exposure levels in Helsinki compared to levels in Perth, Australia (Dingle et al., 1993), and were explained by the higher residential indoor concentrations observed in Helsinki. Overall, of the carbonyl compounds formaldehyde had the highest geometric mean personal exposure concentration observed in Helsinki, followed by acetone, acetaldehyde and nonylaldehyde. Most of the carbonyls were found systematically in personal exposure and residential indoor samples in Helsinki indicating frequent prevalence of these compounds in Finnish indoor environments.

6.2. Relationships between Personal Exposure and Microenvironment Concentrations

6.2.1. Residential Outdoor Environments

Detection of many target compounds was low in residential outdoor microenvironments. In the VOC study, toluene had the highest geometric mean residential outdoor concentration, while for the carbonyl study formaldehyde was detected with the highest geometric mean outdoor concentration. Overall, typical traffic related compounds were the most prevalent VOCs in residential outdoor air in Helsinki.

As the TEAM study indicated at least double median personal exposure concentrations to benzene, ethylbenzene, m&p-xylenes, o-xylene and styrene in North America compared to Helsinki, median residential outdoor levels of these compounds in the TEAM study exceeded levels measured in Helsinki usually by a factor 4 or more (Wallace et al., 1987b). Thus, differences in residential outdoor levels between these two studies were considerably larger than differences between personal exposure concentrations. The closer similarity of personal exposure concentrations was indicative of the large impact of non-outdoor sources on personal exposures of participants of both studies to these VOCs.

In Helsinki, median P/O-ratios exceeded 1.5 for all target compounds except benzene. For 23 compounds the median P/O-ratio was higher than 2.0 and for 10 compounds higher than 4.0 indicating the importance of personal activities and indoor sources in personal VOC exposures of the Helsinki population.

Geometric mean ($1.4 \mu\text{g}/\text{m}^3$) as well as 90th percentile ($2.6 \mu\text{g}/\text{m}^3$) residential outdoor concentrations of benzene in Helsinki did not exceed the new European limit value of

5 $\mu\text{g}/\text{m}^3$ for benzene in the ambient air (CEC, Directive 2000/69/EC). In general, personal exposure and outdoor air concentrations as well as P/O-ratios of benzene appeared much lower than in many other study regions (Wallace, 1990, CEC, 1998, Cocheo et al., 2000), supporting the idea of Helsinki as a “clean” city where many combustion sources have been removed from the immediate environments of the inhabitants and considerable efforts have been made to reduce the quantity of benzene in gasoline. Significantly elevated ($p < 0.05$) levels of typical traffic emitted compounds as m&p-xylenes, ethylbenzene, toluene and nonane were observed in Helsinki, however, outside residences where occupants reported continuous compared to very infrequent traffic or heavy traffic volume.

6.2.2. Residential Indoor Environments

Most of the target compounds in the current study were found systematically in indoor air of Helsinki residences. Toluene had the highest geometric mean residential indoor concentration, followed by the terpenes α -limonene and α -pinene. Residential indoor VOC concentrations observed in EXPOLIS-Helsinki were generally similar to those observed in Helsinki residences around ten years ago (Kostiainen, 1995) (Table 2). Toluene also had there the highest mean residential indoor concentration, followed by α -limonene, α -pinene, p-xylene and hexaldehyde. The terpenes as well as decane, undecane, hexaldehyde and benzaldehyde showed slightly higher indoor concentrations in the EXPOLIS-Helsinki VOC study but the indoor concentrations of benzene were lower in EXPOLIS-Helsinki compared to the study by Kostiainen, supporting the idea that considerable efforts to reduce the quantity of traffic emissions in Helsinki have succeed.

Geometric mean concentration of toluene was in Helsinki lower compared to other studies carried out both in Western Europe and North America (WHO, 1989, Proctor et al., 1991, Wolkoff et al., 1991, Brown et al., 1994, Fellin and Otson, 1994, Brown and Crump, 1996) indicating weaker indoor sources as well as lower residential outdoor concentrations for this compound in Helsinki. In addition to differences in personal exposure concentrations, considerable differences in residential indoor concentrations of compounds with mainly indoor sources indicated different building materials and product types or frequency of their use between Helsinki and North American homes. For example, halogenated compounds appeared to be virtually non-existent in Helsinki but frequent in North American homes (Wolkoff and Nielsen, 2001).

Geometric mean indoor concentrations in Helsinki were higher than residential outdoor concentrations for all target compounds except hexane. In addition, the median I/O-ratios were equal or higher than 1.0 for all target compounds detected (value above LOD) in more than 20% of the residential indoor samples. The median P/I-ratios were lower than 1.0 for compounds that had strong residential indoor sources (d-limonene, α -pinene, 3-carene, 2-methyl-1-propanol, 1-butanol as well as the most carbonyls) indicating that personal exposures to these compounds were reduced by the time spent out of home. In contrast, for traffic related aromatics and alkanes, median P/I-ratios were systematically equal or higher than 1.0 (1.0-1.3) indicating the importance of non-residential activities as e.g., commuting and occupational exposure, in personal exposures to these compounds. However, median P/I-ratios of these compounds were generally lower compared to other personal exposure studies carried out for VOCs both in North America and Western Europe (Wallace et al., 1991, Cocheo et al, 2000, Ilgen et al., 2001b).

In the carbonyl study, formaldehyde had the highest geometric mean residential indoor concentration observed in Helsinki, followed by acetone and acetaldehyde. Indoor residential concentrations of formaldehyde were lower in Helsinki when compared to levels in New Jersey (US) (Zhang et al., 1994) but higher than levels in Boston (US) and Perth (Australia) (Dingle et al., 1993, Reiss et al., 1995). In New Jersey, the samples were collected during the afternoon hours in summer months (periods with high traffic frequency and high photochemical activity) and this may explain the high formaldehyde concentrations observed there. Indoor concentrations of acetaldehyde, acetone and valeraldehyde in residences were generally higher than indoor concentrations observed in New Jersey or Boston. Additional indoor sources or increased source strengths were indicated in Helsinki, especially for valeraldehyde as the I/O-ratios of this compound were considerably higher compared to these two other study centers.

6.2.3. Workplace Environments

In contrast to residential indoor and outdoor measurements that were carried out during the evening and nights, workplaces were measured during the daytime. Measured workplaces were mostly office type buildings located generally in areas with high traffic densities. For this reason traffic emissions had a more important role on measured indoor concentrations of

xylenes, toluene, ethylbenzene, propylbenzene and trimethylbenzenes in ETS-free workplaces compared to residential concentrations in Helsinki.

Geometric mean levels of target compounds were generally higher in residences of Helsinki compared to workplace indoor microenvironments except for 2-ethyl-1-hexanol, benzene, o-xylene and propylbenzene which showed equal concentrations in both. In spite of this, the extreme concentrations were considerably higher in some individual workplaces, especially for alkanes, aromatics and halogenated compounds, reflecting the wide variety of professions and working conditions that the participants of the study represented. The maximum levels of alkanes and aromatics, however, were typically observed in workplaces where the participant reported very high indoor smoking frequency or extensive painting and other renovation activities completed during the last year.

6.2.4. Summary of Relationships

Identification of the roles of different microenvironments and the sources in these microenvironments provide effective mechanisms of controlling personal exposure levels and population exposures to air pollution. Based on simple and multivariate regression models shown in V and this thesis (Table 11), respectively, the roles of microenvironment concentrations in determining personal exposure concentrations to VOCs and carbonyls in Helsinki were summarized (Table 12) into subcategories of target compounds with similar determinants.

Table 12. Subcategories of target VOCs and carbonyls with similar environmental determinants of personal exposure concentrations.

Subcategory	Compounds
<i>Class A.</i> Compounds with low detection in personal exposure samples.	Hexane Cyclohexane Styrene Naphthalene Phenol 1-Octanol 2-Butoxyethanol Trichloroethene Tetrachloroethene 1,1,2-Trichloroethane 1-Methyl-2-pyrrolidinone 2-pentanone 3-Methyl-2-pentanone 2-Hexanone
<i>Class B.</i> Compounds, for which personal exposure concentrations were significantly associated with residential outdoor, residential indoor and workplace concentrations .	Benzaldehyde
<i>Class C.</i> Compounds, for which personal exposure concentrations were significantly associated with residential indoor and workplace concentrations .	Nonane Decane Undecane Propylbenzene Trimethylbenzenes 2-Methyl-1-propanol Propionaldehyde
<i>Class D.</i> Compounds, for which personal exposure concentrations were significantly associated with residential indoor and workplace concentrations and personal activities .	Benzene Toluene Ethylbenzene m&p-Xylenes o-Xylene Hexaldehyde
<i>Class E.</i> Compounds, for which personal exposure concentrations were significantly associated with residential indoor concentrations and personal activities .	2-Ethyl-1-hexanol Octylaldehyde α -Pinene
<i>Class F.</i> Compounds, for which personal exposure concentrations were significantly associated with residential indoor concentrations .	1-Butanol d-Limonene 3-Carene Formaldehyde Acetaldehyde Acetone Valeraldehyde Nonylaldehyde

Benzaldehyde was the only compound, which showed significant ($p < 0.05$) associations between personal exposure and residential outdoor concentrations in addition to residential indoor and workplace concentrations. However, as the quality assurance tests of the study

indicated differences in parallel measurements of PEMs and MEMs for this compound, these correlations may be a result of artifact generation.

Personal exposure concentrations to nonane, decane, undecane, propylbenzene, trimethylbenzenes and 2-methyl-1-propanol showed significant ($p < 0.05$) associations with both residential indoor and workplace concentrations of these compounds and highlighted the importance of these microenvironments for personal exposures. This was supported by the I/O-, P/I- and P/O-ratios observed for these compounds (Table 9). Propionaldehyde was the only compound in the carbonyl study for which personal exposure concentrations showed significant associations with both residential indoor and workplace concentrations of the compound (V).

In addition to residential indoor and workplace concentrations, personal activities such as transport and commuting seemed to play an important role in exposure to the BTEX-compounds as well as exposure to hexaldehyde. This was demonstrated by significant ($p < 0.05$) associations between the "intercept" term and the personal exposure concentrations to these compounds in the multivariate regression analysis. Personal activities were also implicated for the BTEX-compounds by the analysis of the P/I-ratios as the median ratios were in Helsinki equal to or higher than 1.0 for all these compounds (Table 9). Analysis of the residential I/O-ratios suggested that indoor sources of benzene were minor for the non-ETS exposed majority of the population of Helsinki. Moreover, Edwards and Jantunen (2001) reported that the strongest single predictor of benzene exposure for non-ETS exposed participants in Helsinki was residential indoor benzene concentration – mostly penetrated from ambient air – followed by factors such as "time spent in a car", "time spent in the indoor environment", "workplace concentration" and "time spent in the home workshop".

In addition to residential indoor concentrations, personal activities such as use of perfumes, colognes, soaps and other personal products indicated a role ($p < 0.05$) in exposure to 2-ethyl-1-hexanol, octylaldehyde and α -pinene. In general, however, the residential indoor environment was the strongest single microenvironment in predicting personal VOC exposure levels in Helsinki. Indoor concentrations showed significant ($p < 0.05$) associations with personal exposure concentrations for all VOCs included in the multivariate regression analysis. This agrees with conclusions of other large exposure studies (Wallace, 1993, Hoffman et al., 2000, Ilgen et al., 2001b) and can be explained by the fact that study participants in Helsinki spent, on average, 60% of their daily time in residences where the

highest VOC concentrations were typically observed. The compounds in multivariate regression analysis that showed significant ($p < 0.05$) associations only between personal exposure and residential indoor concentrations were 1-butanol, d-limonene and 3-carene. They had median residential I/O-ratios higher than 7.5 indicating the dominance of residential indoor VOC sources in exposures to these compounds. In addition, in the simple regression analysis for the carbonyl study compounds, personal exposure concentrations were significantly ($p < 0.05$) associated only with residential indoor concentrations for six out of the nine compounds included in the analysis and explained more than 50% of the exposure variance of acetone, hexaldehyde and nonylaldehyde.

6.3. Source Apportionment

The dominant sources for total variance of VOC concentrations were different in each ETS-free microenvironment monitored in Helsinki. Furthermore, the VOC composition of personal exposure samples reflected the complex mixture of microenvironments in which the participants spent their time, with e.g., cleaning products from the residential indoor environments and product emissions from workplace environments identified as individual factors in personal exposure samples. The VOC analysis of the EXPOLIS study showed that accurate estimation of exposures that might explain health effects requires personal monitoring as data collected just in one microenvironment would give a distorted picture of the exposures.

The two strongest source factors in personal exposure concentrations of non-ETS exposed participants together accounted for 36% of the total exposure variance and were both related to traffic. Overall, personal exposure concentrations to traffic related VOCs exceeded those in the residential outdoor microenvironments, but were closely related to concentrations observed in the residential indoor and workplace microenvironments. This suggests that a significant portion of personal exposure to these compounds was due to indoor sources (other than ETS). Such sources have been identified in other studies as e.g., consumer products and building materials (Wadden et al., 1986, Brown et al., 1994, Fellin and Otson, 1994, Brown and Crump, 1996, Hoffman et al., 2000, Ilgen et al., 2001a).

The strongest and the second strongest source factors in the residential outdoor environment together accounted for more than half of the sample variance and were both associated with

motor vehicle emissions. The strongest factor was related more to long-range transport of VOC pollutants and the second strongest to local emissions. The variability in residential indoor VOC concentrations was dominated by two factors that accounted both for 18% of the total variance and were associated with emissions from indoor sources such as cleaning products, fragrances, consumer products and building products (e.g., particle board), and to emissions from local traffic sources. Interestingly, the relative dominance of local traffic and long-range transport factors were reversed in the residential outdoor environment and the residential indoor environment although both microenvironments were sampled at the same time.

The strongest source factor accounted 24% of the total variance in workplace microenvironments and was identified as local traffic emissions. Although residential indoor levels were measured mainly during evenings and nights when traffic sources would be smaller and workplace levels were measured during the days when traffic sources would be larger, it was interesting to note that the residential indoor levels of traffic-related compounds were equal to or exceeded workplace levels. Thus, localized indoor sources seemed to have a large impact on microenvironment concentrations and care must be taken in attributing the magnitude of personal exposures to actual traffic sources. For example, analysis of residential I/O-ratios suggested that indoor sources of benzene were small for the majority of the population of Helsinki. However, Edwards and Jantunen (2001) demonstrated that 10% of the houses in Helsinki indicated substantial indoor sources for benzene. Thus, substantial reduction in benzene exposures could be achieved by focusing on these houses.

Strong inter-compound correlations of most carbonyl compounds in residential indoor microenvironments suggest common sources for these compounds, such as cleaning products, fragrances, consumer products and building materials. These indoor sources played, overall, a dominant role in personal exposures to carbonyl compounds. Studies concerning indoor air chemistry of VOC pollutants have shown that chemical reactions of unsaturated organic compounds as terpenes with oxidants as O_3 and NO_x occur indoors and can produce additional air pollutants in indoor environments (Weschler and Shields, 1997, Wolkoff et al., 2000, Wolkoff and Nielsen, 2001). Carbonyl compounds such as formaldehyde and acetaldehyde and other C_5 - C_{10} aldehydes are known products of these reactions (Weschler and Shields, 1997, Shaughnessy et al., 2001). In EXPOLIS-Helsinki, the VOC factor associated with air fresheners and elevated d-limonene concentrations in the workplace environment correlated negatively with formaldehyde, acetaldehyde, benzaldehyde and

heptylaldehyde. This finding may indicate indoor air chemistry between terpenes and increased daytime O₃ levels in workplaces of Helsinki, similar to recent findings by Shaughnessy et al. (2001).

7. CONCLUSIONS

Toluene had the highest geometric mean personal VOC exposure concentration ($16.3 \mu\text{g}/\text{m}^3$) within the population of Helsinki, followed by m&p-xylenes ($8.7 \mu\text{g}/\text{m}^3$), d-limonene ($8.5 \mu\text{g}/\text{m}^3$), hexaldehyde ($6.8 \mu\text{g}/\text{m}^3$) and α -pinene ($6.5 \mu\text{g}/\text{m}^3$). Formaldehyde was the carbonyl compound with the highest geometric mean personal exposure concentration (18.7 ppb), followed by acetone (8.8 ppb) and acetaldehyde (6.8 ppb). The geometric mean personal exposure concentration to benzene ($2.5 \mu\text{g}/\text{m}^3$) was lower in Helsinki than in studies in North America and Western Europe. Geometric mean residential indoor concentrations in Helsinki were higher than outdoor concentrations for all target compounds except hexane. Inside the residences toluene had the highest geometric mean concentration ($14.6 \mu\text{g}/\text{m}^3$) among the VOCs, and formaldehyde (28.3 ppb) among the carbonyls. Geometric mean levels of VOCs and carbonyls were generally higher in the residences than in the workplaces. The extreme concentrations, however, were considerable higher in some individual workplaces. This was especially true for alkanes, aromatics and halogenated compounds, reflecting the variety of professions as well as working conditions that the participants represented.

Multivariate regression model using residential outdoor, residential indoor and workplace air VOC concentrations for predicting personal exposure concentration of the non-ETS exposed Helsinki population accounted for 39% (benzene) to 77% (α -pinene) of the personal exposure variance. Residential indoor and workplace concentrations were, compared to residential outdoor air levels, much stronger predictors of personal exposure concentrations to VOCs and carbonyls. The median P/I-ratios were lower than 1.0 for compounds that had strong residential indoor sources (terpenes, 2-methyl-1-propanol, 1-butanol as well as the most carbonyls) indicating that personal exposures to these compounds were reduced by the time spent out of home. In contrast, for traffic related aromatics and alkanes, median P/I-ratios were systematically equal or higher than 1.0 indicating the importance of non-residential activities as e.g., commuting and occupational exposure, in personal exposures to these compounds.

The significance of tobacco smoke as a source of VOC exposure of the Helsinki population was demonstrated clearly in the current study. Geometric mean exposures to benzene, toluene, styrene, ethylbenzene, trimethylbenzenes, m&p-xylenes and o-xylene were 1.2-1.5 times higher for the population of ETS exposed participants than for those not exposed.

The major VOC source categories were different in each microenvironment. The two strongest source factors together accounted for 36% of the total exposure variance (for participants not exposed to ETS). Both reflected traffic related sources. VOC levels in residential indoor and workplace environments, however, were substantially higher than levels observed in residential outdoor environments for most traffic related compounds indicating significant additional indoor sources, such as consumer products and building materials for these compounds. Thus, localized indoor sources may have a large impact on microenvironment concentrations and great care must be taken in attributing the magnitudes of personal exposures to specific sources identified in the outdoor environment. Most of the sampled carbonyls were found systematically inside the residences, indicating frequent existence of their sources in Finnish indoor environments. Strong inter-compound correlations of carbonyls in residential indoor microenvironments suggested common sources such as cleaning products, fragrances, consumer products and building materials for these compounds. The VOC source factor associated with air fresheners (particularly α -limonene concentrations) in the workplace environment correlated negatively with formaldehyde, acetaldehyde, benzaldehyde and heptylaldehyde. This finding may indicate indoor air chemistry between terpenes and increased daytime O_3 levels in workplaces of Helsinki, similar to recent findings by Shaughnessy et al. (2001).

Considerable differences in median personal exposure concentrations for compounds with mainly indoor sources suggested differences in product types and building materials between Finland, Germany and North America. Good examples of this are the halogenated compounds that are frequently observed in Northern American exposure samples, but were absent in Helsinki. Residential indoor concentrations were the strongest predictors of VOC exposure levels within the population of Helsinki showing significant associations with personal exposure concentrations to all VOCs included in the multivariate regression analysis. In addition, this analysis indicated that exposure in traffic (as interpreted from the “intercept” term of the regression analysis) has significant associations with personal exposure concentrations to BTEX-compounds. These findings showed that accurate estimation of exposures to assess potential health risks requires personal monitoring as data collected in one or two microenvironments could underestimate exposures, and hide significant sources.

REFERENCES

Andersson K, Bakke JV, Bjørseth O, Bornehag CG, Clausen G, Hongslo JK, Kjellman M, Kjaergaard S, Levy F, Mølhave L, Skerfving S, Sundell J. TVOC and Health in Non-Industrial Indoor Environments. *Indoor Air* 1997; 7: 78-91.

Arnts RR, Tejda SB. 2,4-Dinitrophenylhydrazine-Coated Silica Gel Cartridge Method for Determination of Formaldehyde in Air: Identification of an Ozone Interference. *Environ Sci Technol* 1989; 23: 1428-1430.

Baugh J, Ray W, Black F. Motor Vehicle Emissions under Reduced Ambient Temperature Idle Operating Conditions. *Atmos Environ* 1987; 21: 2077-2082.

Barrefors G, Petersson G. Assessment of Ambient Volatile Hydrocarbons from Tobacco Smoke and from Vehicle Emissions. *J of Chromatography* 1993; 643: 71-76.

Brown SK, Sim MR, Abramson MJ, Gray CN. Concentrations of Volatile Organic Compounds in Indoor Air – A Review. *Indoor Air* 1994; 4: 123-134.

Brown VM, Crump DR. Volatile Organic Compounds. In: Berry RW, Brown VM, Coward SKD, Crump DR, Gavin M, Grimes, CP, Higham DF, Hull AV, Hunter CA, Jeffrey IG, Lea AV, Llwellyn JW, Raw GJ, eds. *Indoor Air Quality in Homes. The Building Research Establishment Indoor Environment Study. Part 1. Construction Research Communications.* London, UK, 1996.

Brown SK. Chamber Assessment of Formaldehyde and VOC Emissions from Wood-Based Panels. *Indoor Air* 1999; 9: 209-215.

Brown SK. Volatile Organic Pollutants in New and Established Buildings in Melbourne, Australia. *Indoor Air* 2002; 12: 55-63.

Calvert JG, Madronich SJ. Theoretical Study of the Initial Products of the Atmospheric Oxidation of Hydrocarbons. *J of Geophysical Research* 1987; 92: 2211-2220.

Carlier P, Hannachi H, Mouvier, G. The Chemistry of Carbonyl Compounds in the Atmosphere - A Review. *Atmos Environ* 1986; 20: 2079-2099.

Chan, CC, Özkaynak H, Spengler JD, Sheldon L. Driver Exposure to Volatile Organic Compounds, CO, Ozone, and NO₂ under Different Driving Conditions. *Environ Sci Technol* 1991a; 25: 964-972.

Chan CC, Spengler J, Özkaynak H, Lefkopoulou M. Commuter Exposures to VOCs in Boston, Massachusetts. *J Air Waste Manage Assoc* 1991b; 41: 1594-1600.

Chan CC, Lin SH, Her GR. Student's Exposure to Volatile Organic Compounds while Commuting by Motorcycle and Bus in Taipei City. *J Air Waste Manage Assoc* 1993; 43: 1231-1238.

Chan CC, Lin SH, Her GR. Office Workers Exposure to Volatile Organic Compounds while Commuting and Working in Taipei City. *Atmos Environ* 1994; 28: 2351-2359.

Chang JC, Guo Z, Fortmann R, Lao HC. Characterization and Reduction of Formaldehyde Emissions from a Low-VOC Latex Paint. *Indoor Air* 2002; 12: 10-16.

Ciccioli P, Brancaleoni E, Frattoni M, Di Palo V, Valentini R, Tirone G, Seufert G, Bertin N, Hansen U, Csiky O, Lenz R, Sharma M. Emission of Reactive Terpene Compounds from Orange Orchards and Their Removal by Within-Canopy Processes. *J of Geophysical Research* 1999; 104: 8077-8094.

Cocheo V, Sacco P, Boaretto C, De Saeger E, Perez Ballesta P, Skov H, Goelen E, Gonzalez N, Baeza Caracena A. Urban Benzene and Population Exposure. *Nature* 2000; 404: 141-142.

Colls J. *Air Pollution - an Introduction*. E&FN Spon, an Imprint of Chapman&Hall. London, United Kingdom. 1997.

Commission of the European Communities, Directorate - General XII for Science, Research and Development. COST 613/2 Report Series on Air Pollution Epidemiology. Report Number 1: Exposure Assessment, EUR 14345 EN. 1991.

Commission of the European Communities. Directive 93/67/EEC. 1993.

Commission of the European Communities. Directive 1994/63/EC. 1994

Commission of the European Communities. Council Directive on Ambient Air Quality Assessment and Management. Working Group on Benzene. Position Paper. 1998.

Commission of the European Communities. Directive 2000/69/EC. 2000.

Cooper SD, Raymer JH, Pellizzari ED, Thomas KW. The Identification of Polar Organic Compounds Found in Consumer Products and Their Toxicological Properties. *J Expo Anal Environ Epidemiol* 1995; 5: 57-75.

Cox SS, Little JC, Hodgson AT. Measuring Concentrations of Volatile Organic Compounds in Vinyl Flooring. *J Air Waste Manage Assoc* 2001; 51: 1195-1201.

Daisey JM, Hodgson AT, Fisk WJ, Mendell MJ, Brinke JT. Volatile Organic Compounds in Twelve California Office Buildings: Classes, Concentrations and Sources. *Atmos Environ* 1994; 28: 3557-3562.

De Bortoli M, Knoppel H, Pecchio E, Peil A, Rogora L, Schauenberg H, Vissers H. Integrating "Real Life" Measurements of Organic Pollution in Indoor and Outdoor Air of Homes in Northern Italy. *Indoor Air* 1984; 4: 21-26.

Dingle P, Shuwei H, Murray F. Personal Exposure to Formaldehyde. In *Proceedings of Indoor Air '93*. Saarela K, Kalliokoski P, Seppänen O, Eds. *Indoor Air '93*. Helsinki, Finland. 1993. pp. 293-298.

Dor F, Le Moullec Y, Festy B. Exposure of City Residents to Carbon Monoxide and Monocyclic Aromatic Hydrocarbons during Commuting Trips in the Paris Metropolitan Area. *J Air Waste Manage Assoc* 1995; 45: 103-110.

Edwards RD, Jantunen MJ. Benzene Exposure in Helsinki, Finland. *Atmos Environ* 2001; 35: 1411-1420.

Fellin P, Otson R. Assessment of the Influence of Climatic Factors on Concentration Levels of Volatile Organic Compounds (VOCs) in Canadian Homes. *Atmos Environ* 1994; 28: 3581-3586.

Fortmann R, Roache N, Chang JC, Guo Z. Characterization of Emissions of Volatile Organic Compounds from Interior Alkyd Paint. *J Air Waste Manage Assoc* 1998; 48: 931-940.

Gordon GE. Receptor Models. *Environ Sci Technol* 1980; 14: 792-800.

Granby K, Christensen CS, Lohse C. Urban and Semi-Rural Observations of Carboxylic Acids and Carbonyls. *Atmos Environ* 1997; 31: 1403-1415.

Grosjean E, Grosjean D, Fraser MP, Cass GR. Air Quality Model Evaluation Data for Organics. 2. C₁-C₁₄ Carbonyls in Los Angeles Air. *Environ Sci Technol* 1996; 30: 2687-2703.

Hartwell TD, Perritt RL, Pellizzari ED, Michael LC. Results from the 1987 Total Exposure Assessment Methodology (TEAM) Study in Southern California. *Atmos Environ* 1992; 26A: 1519-1527.

Helmig D, Arey J. Organic Chemicals in the Air at Whitaker's Forest/Sierra Nevada Mountains, California. *Sci Total Environ* 1992; 112: 233-250.

Henry CR, Lewis CW, Hopke PK, Williamson HJ. Review of Receptor Model Fundamentals. *Atmos Environ* 1984; 18: 1507-1515

Hodgson AT, Rudd AF, Beal D, Chandra S. Volatile Organic Compound Concentrations and Emission Rates in New Manufactured and Site-Built Houses. *Indoor Air* 2000; 10: 178-192.

Hoffmann K, Schwabe R, Krause C, Schultz C, Seifert B, Ullrich D. Umwelt-Survey 1990/91. Band IV des Institutes für Wasser-, Boden- und Lufthygiene des Bundesgesundheitsamtes. Personengebundene Exposition Gegenüber Flüchtig Organischen Verbindungen in den Alten Bundesländern. WaBoLu-Hefte, Band 4, Berlin, Germany. 1996.

Hoffmann K, Krause C, Seifert B, Ullrich D. The German Environmental Survey 1990/1992 (GerES II): Sources of Personal Exposure to Volatile Organic Compounds. *J Exp Anal Environ Epidemiol* 2000; 10: 115-125.

Hornung RW, Reed LD. Estimating of Average Concentration in the Presence of Nondetectable Values. *Appl Occup Envir Hyg* 1990; 5: 46-51.

Houghton JT, Meira Filho LG, Callander BA, Harris N, Kattenberg A, Maskell K. *Climate Change 1995: The Science of Climate Change*. IPCC, Cambridge University Press. Great Britan. 1996.

Humfrey C, Shuker L, Harrison P. IEH Assessment on Indoor Air Quality in Home, Assessment A2; Medical Research Council, Institute for Environment and Health. Leicester, UK, 1996: pp.151-176.

Ilgén E, Karfich N, Levsen K, Angerer J, Schneider P, Heinrich J, Wichmann HE, Dunemann L, Begerow J. Aromatic Hydrocarbons in the Atmospheric Environment: Part I. Indoor versus Outdoor Sources, the Influence of Traffic. *Atmos Environ* 2001a; 35: 1235-1252.

Ilgén E, Levsen K, Angerer J, Schneider P, Heinrich J, Wichmann HE. Aromatic Hydrocarbons in the Atmospheric Environment. Part III. Personal Monitoring. *Atmos Environ* 2001b; 35: 1265-1279.

Jantunen MJ, Hänninen O, Katsouyanni K, Knöppel H, Kuenzli N, Lebret E, Maroni M, Saarela K, Sram R, Zmirou D. Air Pollution Exposure in European Cities: The "EXPOLIS" Study. *J Expo Anal Environ Epidemiol* 1998; 8: 495-518.

Jantunen MJ, Katsouyanni K, Knöppel H, Kuenzli N, Lebret E, Maroni M, Saarela K, Srám R, Zmirou D. Final Report: Air Pollution Exposure in European Cities: The EXPOLIS Study. Kuopio, Finland: National Public Health Institute, 1999. *Kansanterveyslaitoksen Julkaisuja*, B16/1999.

Jantunen M. Risk Estimation, Management and Perception. In the Urban Atmosphere and Its Effects; *Air Pollution Reviews*. Vol. 1. Brimblecombe P, Maynard RL, Eds.; Imperial College Press, London, United Kingdom. 2001; pp. 301-344.

Jo WK, Weisel CP, Liroy PJ. Chloroform Exposure and the Health Risk Associated with Multiple Uses of Chlorinated Tap Water. *Risk Analysis* 1990; 10: 581-585.

Jo WK, Choi SJ. Vehicle Occupants Exposure to Aromatic Volatile Organic Compounds while Commuting on an Urban-Suburban Route in Korea. *J Air Waste Manage Assoc* 1996; 46: 749-754.

Jo WK, Song KB. Exposure to Volatile Organic Compounds for Individuals with Occupations Associated with Potential Exposure to Motor Vehicle Exhaust and/or Gasoline Vapour Emissions. *Sci Total Environ* 2001; 26: 25-37.

Jo WK, Yu CH. Public Bus and Taxicab Drivers' Work-time Exposure to Aromatic Volatile Organic Compounds. *Environ Res* 2001; 86: 66-72.

Kao AS, Friedlander SK. Frequency Distributions of PM₁₀ Chemical Components and Their Sources. *Environ. Sci Technol* 1995; 29: 19-28.

Kim YM, Harrad S, Harrison RM. Concentrations and Sources of VOCs in Urban Domestic and Public Microenvironments. *Environ. Sci Technol* 2001; 35: 997-1004.

Knöppel H, Schauenburg H. Screening of Household Products for the Emission of Volatile Organic Compounds. *Environ Int* 1989; 15: 413-418.

Koistinen K, Kousa A, Tenhola V, Hänninen O, Oglesby L, Georgoulis L, Kuenzli N, Jantunen MJ. Quality Assurance Procedures and Pilot Results of the EXPOLIS Study. *J Air Waste Manage Assoc* 1999; 49: 1212-1220.

Koistinen K, Hänninen O, Rotko T, Edwards R, Moschandreas D, Jantunen M. Behavioral and Environmental Determinants of Personal Exposures to PM_{2.5} in EXPOLIS-Helsinki, Finland. *Atmos Environ* 2001; 35: 2473-2481.

Koistinen K, Edwards R, Mathys P, Ruuskanen J, Kuenzli N, Jantunen M. Sources of PM_{2.5} in Personal Exposures and Residential Indoor, Outdoor and Workplace Microenvironments in EXPOLIS-Helsinki, Finland. *Scand J Work Environ Health* 2003, in press.

Kostiainen R. Volatile Organic Compounds in the Indoor Air of Normal and Sick Houses. *Atmos Environ* 1995; 29: 693-702.

Kousa A, Monn C, Rotko T, Alm S, Oglesby L, Jantunen MJ. Personal Exposure to NO₂ in the EXPOLIS-Study: Relation to Residential Indoor, Outdoor and Workplace Concentrations in Basel, Helsinki and Prague. *Atmos Environ* 2001; 35: 3405-3412.

Kousa A, Oglesby L, Koistinen K, Kuenzli N, Jantunen M. Exposure Chain of Urban Air PM_{2.5} – Associations Between Ambient Fixed Site, Residential Outdoor, Indoor, Workplace and Personal Exposures in Four European Cities in the EXPOLIS-Study. *Atmos Environ* 2002; 36: 3031-3039.

Krause C, Mailahn W, Nagel R, Schultz C, Seifert B, Ullrich D. Occurrence of Volatile Organic Compounds in the Air of 500 Homes in the Federal Republic of Germany. In: *Proceedings of Indoor Air '87, Vol. 1*. Institute for Soil, Water and Air Hygiene, Berlin, Germany. 1987: pp. 102-106.

Lawryk JL, Liroy PJ, Weisel CP. Exposure to Volatile Organic Compounds In The Passenger Compartment of Automobiles During periods of Normal and Malfunctioning Operation. *J Expo Anal Environ Epidemiol* 1995; 5: 511-531.

Lebret E, Van de Wiel HJ, Bos HP, Noij D, Boleij JSM. Volatile Hydrocarbons in Dutch Homes. *Indoor Air* 1984; 4: 169-174.

Lewis RG, Gordon SM. *Principles of Environmental Sampling*. Keith LH, Ed.; ACS, Washington, DC. 1996; pp. 401-470.

Liroy PJ. Assessing Total Human Exposure to Contaminants. *Environ Sci Technol* 1990; 24: 938-945.

Lloyd AC, Atkinson R, Lurmann FW, Nitta B. *Atmos Environ* 1983; 17: 1931-1950.

Löfgren L, Persson K, Strömvall AM, Persson G. Exposure of Commuters to Volatile Aromatic Hydrocarbons from Petrol Exhaust. *Sci Total Environ* 1991; 108: 225-233.

Manahan SE. Environmental Chemistry. 6th Edition; Lewis Publishers. US, 1994.

Maroni M, Seifert B, Lindvall T. Indoor Air Quality, A Comprehensive Reference Book; Vol. 3; Elsevier Science. Amsterdam, The Netherlands, 1995.

McHugh CA, Carruthers DJ, Edmunds HA. ADMS-Urban: An Air Quality Management System for Traffic, Domestic and Industrial Pollution. *Int J Environ Poll* 1997; 8: 666-674.

Miller JC, Miller JN. Statistics for Analytical Chemistry. Ellis Horwood Limited, Halsted Press, John Wiley and Sons: New York, 1986.

Moriske HJ, Drews M, Ebert G, Menk G, Scheller M, Schondube M, Konieczny L. Indoor Air Pollution by Different Heating Systems. *Toxicol Lett* 1996; 88: 349-354.

Mølhave L. Volatile Organic Compounds, Indoor Air Quality and Health. In: Proceedings of Indoor Air '90, Vol. 5. International Conference on Indoor Air Quality and Climate. Ottawa, Canada, 1990: pp. 15-33.

Mølhave L, Kjaergaard SK, Hempel-Jorgenson A, Juto JE, Andersson K, Stridh G, Falk J. The Eye Irritation and Odor Potencies of Four Terpenes which Major Constituents of the Emissions of VOCs from Nordic Soft Woods. *Indoor Air* 2000; 10: 315-318.

Müller K. Determination of Aldehydes and Ketones in the Atmosphere-A Comparative Long Time Study at an Urban and a Rural Site in Eastern Germany. *Chemosphere* 1997; 30: 2093-2106.

Namiesnik J, Gorecki T, Kozdron-Zabiegala B, Lukasiak J. Indoor Air Quality (IAQ), Pollutants, Their Sources and Concentration Levels. *Building and Environment* 1992; 27: 339-356.

National Academy of Sciences: Human exposure assessment for airborne pollutants: Advances and Opportunities. National Academy Press. Washington, D.C. 1991.

Nordic Committee on Building Regulations (NKB). Testing and Discussion of the Proposed Criteria for the Ability of Chemical Substances to Cause Allergy and Hypersensitivity in the Skin and Lower Airways. NKB Committee and Work Reports 1994:03E. Painatuskeskus Oy. Helsinki, Finland. 1994.

Oglesby L, Rotko T, Kruetli P, Boudet C, Kruize H, Jantunen MJ, Kuenzli N. Personal Exposure Assessment Studies May Suffer from Exposure Relevant Selection Bias. *J Expo Anal Environ Epidemiol* 2000; 10: 251-266.

Ong CN, Koh D, Foo SC, Kok PW, Ong HY, Aw TC. Volatile Organic Solvents in Correction Fluids: Identification and Potential Hazards. *Bulletin of Environmental Contamination and Toxicology* 1993; 50: 787-793.

Ott WR. Total Human Exposure. *Environ Sci Technol* 1985; 19: 880-886.

Ott, W. Human Exposure Assessment: The Birth of a New Science. *J Expo Anal Environ Epidemiol* 1995; 5: 449-472.

Pellizzari ED, Perritt K, Hartwell TD, Michael LC, Whitmore R, Handy RW, Smith D, Zelon H. Total Exposure Assessment Methodology (TEAM) Study: Elizabeth and Bayonne, New Jersey; Devils Lake, North Dakota; and Greensboro, North Carolina. Vol. 2. US EPA, Washington DC, US. 1987a.

Pellizzari ED, Perritt K, Hartwell TD, Whitmore R, Handy RW, Smith D, Zelon H. Total Exposure Assessment Methodology (TEAM) Study: Selected Communities in Northern and Southern California. Vol. 3, US EPA, Washington DC, US. 1987b.

Peneulas J, Liusia J. Seasonal Patterns of Non-Terpenoid C₆-C₁₀ VOC Emissions from Seven Mediterranean Woody Species. *Chemosphere* 2001; 45: 237-244.

Proctor CJ, Warren ND, Bevan MAJ, Baker-Rogers J. A Comparison of Methods of Assessing Exposure to Environmental Tobacco Smoke in Non-Smoking British Women. *Environ Int* 1991; 17: 287-297.

Raaschou-Nielsen O, Lohse C, Thomsen BL, Skov H, Olsen JH. Ambient Air Levels and the Exposure of Children to Benzene, Toluene and Xylenes in Denmark. *Environ Res* 1997; 75: 149-159.

Reiss R, Ryan PB, Tibbetts SJ, Koutrakis P. Measurement of Organic Acids, Aldehydes, and Ketones in Residential Environments and Their Relation to Ozone. *J Air Waste Manage Assoc* 1995; 45: 811-822.

Roberts JW. Everyday Exposure to Toxic Pollutants. *Scientific American* 1998; February: 68-77.

Romieu I, Meneses F, Ruiz S, Sienna JJ, Huerta J, White MC, Etzel RA. Effects of Air Pollution on the Respiratory Health of Asthmatic Children Living in Mexico City. *American Journal of Respiratory and Critical Care Medicine* 1996; 154: 300-307.

Rotko T, Koistinen K, Hänninen O, Jantunen M. Sociodemographic Descriptors of Personal Exposure to Fine Particles (PM_{2.5}) in EXPOLIS-Helsinki. *J Expo Anal Environ Epidemiol* 2000a; 10: 385-393.

Rotko T, Oglesby L, Kuenzli N, Jantunen MJ. Population Sampling in European Air Pollution Exposure Study, EXPOLIS: Comparisons Between the Cities and Representativity of the Samples. *J Expo Anal Environ Epidemiol* 2000b; 10: 355-364.

Rotko T, Kousa A, Alm S, Jantunen MJ. Exposures to Nitrogen Dioxide in EXPOLIS-Helsinki: Microenvironment, Behavioral and Sociodemographic Factors. *J Expo Anal Environ Epidemiol* 2001; 11: 216-223.

Saarinen L. Recent Development of Exposure to Gasoline in the Distribution Chain. *People and Work Research Reports* 51. FIOH. Helsinki, Finland. 2002.

Sack TM, Steele DH, Hammerstrom K, Remmers J. A Survey of Household Products for Volatile Organic Compounds. *Atmos Environ* 1992; 26: 1063-1070.

Salonen RO. Adverse Health Effects Caused by Outdoor Air Pollution in Finland. *FAPP News* 1991; 15: 36-40.

Schwab M, Colome SD, Spengler JD, Ryan PB, Billick IH. Activity Patterns Applied to Pollutant Exposure Assessment: Data from a Personal Monitoring Study in Los Angeles. *Toxicology and Industrial Health* 1990; 6: 517-532.

Schwarz J. Air Pollution and Hospital Admissions for Respiratory Disease. *Epidemiology* 1996; 7: 20-28.

Seinfeld JH, Pandis SN. *Atmospheric Chemistry and Physics: from Air Pollution to Climate Change*. John Wiley & Sons Inc: New York, 1998.

Shaughnessy RJ, McDaniels TJ, Weschler CJ. Indoor Chemistry: Ozone and Volatile Organic Compounds Found in Tobacco Smoke. *Environ Sci Technol* 2001; 35: 2758-2764.

Sheldon LS, Eaton C, Hartwell TD, Zelon HS, Pellizzari ED. *Indoor Air Quality in Public Buildings, Vol II (600/6-88/009b)*, US EPA, Research Triangle Park, NC, US. 1988.

Shepson PB, Hastie DR, Schiff HI, Polizzi M, Bottenheim JW, Anlauf K, Mackay GI, Karecki DR. Atmospheric Concentrations and Temporal Variations of C₁-C₃ Carbonyl Compounds at Two Rural Sites in Central Ontario. *Atmos Environ* 1991; 25A: 2001-2015.

Sillmann S. The Relation between Ozone, NO_x and Hydrocarbons in Urban and Polluted Rural Environment, *Atmos Environ* 1999; 33: 1821-1845.

Skov H, Hansen AB, Lorenzen G, Andersen HV, Løfstrøm P, Christensen CS. Benzene Exposure and the Effect of Traffic Pollution in Copenhagen, Denmark. *Atmos Environ* 2001; 35: 2463-2471.

Spix C, Anderson HR, Schwarz J, Vigotti MA, LeTerte A, Vonk JM, Touloumi G, Balducci F, Piekarksi T, Bacharova L, Tobias A, Pönkä A, Katsouyanni K. Short-terms Effects of Air Pollution on Hospital Admissions of Respiratory Diseases in Europe: a Quantitative Summary of APHEA Study Results. *Arch of Environ Health* 1998; 53: 54-64.

Tischenor BA, Sparks LE, White JB, Jackson MD. Evaluating Sources of Indoor Air Pollution. *J Air Waste Manage Assoc* 1990; 41: 487-492.

Ullrich D, Brenske KR, Heinrich J, Hoffmann K, Ung L, Seifert B. Volatile Organic Compounds: comparison of Personal Exposure and Indoor Air Quality Measurements. Proceedings of the 7th International Conference on Indoor Air Quality and Climate. Vol. 4, Nagoya, Japan. 1996. pp. 301-306.

US Environmental Protection Agency. The Clean Air Act (amended through 31 December 1990) (CAA); 42 US Code 74.01-76.26: US Government Printing Office: Washington, D.C, 1991.

Wadden AR, Uno I, Wakamatsu S. Source Discrimination of Short-term Hydrocarbon Samples Measured Aloft. Environ Sci Technol 1986; 20: 473-483.

Wainman T, Zhang J, Weschler CJ, Liroy PJ. Ozone and Limonene in Indoor Air: A Source of Sub-micron Particle Exposure. Environ Health Perspect 2000; 108: 1139-1145.

Wallace LA, Pellizzari ED. Personal Air Exposures and Breath Concentrations of Benzene and Other Volatile Hydrocarbons for Smokers and Non-smokers. Toxicol Letters 1986; 35: 113-116.

Wallace LA. The Total Exposure Assessment Methodology (TEAM) Study: Summary and Analysis. Vol. 1. EPA. 600/6-87/002A. US EPA, Washington DC, US. 1987.

Wallace LA, Pellizzari E, Hartwell, T, Perritt K, Ziegenfus R. Exposures to Benzene and Other Volatile Organic Compounds from Active and Passive Smoking. Arch Environ Health 1987a; 42: 272-279.

Wallace LA, Pellizzari ED, Hartwell TD, Sparacino C, Whitmore R, Sheldon L, Zelon H, Perritt R. The TEAM Study: Personal Exposures to Toxic Substances in Air, Drinking Water, and Breath of 400 Residents of New Jersey, North Carolina, and North Dakota. Environ Res 1987b; 43: 290-307.

Wallace LA, Pellizzari ED, Hartwell TD, Davis V, Michael LC, Whitmore RW. The Influence of Personal Activities on Exposure to Volatile Organic Compounds. Environ Res 1989; 50: 37-55.

Wallace LA. Major Sources of Exposure to Benzene and Other Volatile Organic Compounds. *Risk Analysis* 1990; 10: 59-64.

Wallace LA. Volatile Organic Chemicals. In *Indoor Air Pollution: A Health Perspective*. Samet J and Spengler J, Eds.; John Hopkins Univ. Press, Baltimore MD, US. 1991.

Wallace L, Nelson W, Ziegenfus R, Pellizzari E, Michael L, Whitmore R, Zelon H, Hartwell T, Perritt R, Westerdahl D. The Los Angeles TEAM Study: Personal Exposures, Indoor-Outdoor Air Concentrations, and Breath Concentrations of 25 Volatile Organic Compounds. *J. Expo Anal Environ Epidemiol* 1991; 1: 157-192.

Wallace L. A Decade of Studies of Human Exposures: What Have We Learned? *Risk Analysis* 1993; 135-139.

Wallace LA. Environmental Exposure to Benzene: An Update. *Environ Health Perspect* 1996a; 104: 1129-1136.

Wallace LA. Personal Exposure to VOCs in the Home: Concentrations, Sources and Risks. In Humfrey C, Shuker L, Harrison P. *IEH Assessment on Indoor Air Quality in Home, Assessment A2*; Medical Research Council, Institute for Environment and Health. Leicester, UK, 1996b: pp.338-376.

Wallace L, Buckley T, Pellizzari E, Gordon S. Breath Measurements as Volatile Organic Compound Biomarkers. *Environ Health Perspect* 1996; 104, Suppl 5: 861-869.

Watson JG, Chow JC, Fujita EM. Review of Volatile Organic Compound Source Apportionment by Chemical Mass Balance. *Atmos Environ* 2001; 35: 1567-1584.

Van Wijnen JH, Verhoeff AP, Jans HWA, Van Bruggen M. The Exposure of Cyclists, Car drivers and Pedestrians to Traffic-related Air Pollutants. *Int Arch Occup Environ Health* 1995; 67: 187-193.

Weisel CP, Lawryk NJ, Lioy PJ. Exposure to Emissions from Gasoline within Automobile Cabins. *J Expo Anal Environ Epidemiol* 1992; 2: 79-96.

Weschler CJ, Shields HC. Potential Reactions Among Indoor Pollutants. *Atmos Environ* 1997; 31: 3487-3495.

WHO. Indoor Air Quality: Organic Pollutants. European Reports and Studies No. 111. 1989. Copenhagen, Denmark.

WHO. Guidelines for Air Quality. 2000. Geneva, Switzerland.

Wixtrom RN, Brown SL. Individual and Population Exposure to Gasoline. *J Expo Anal Environ Epidemiol* 1992; 2: 23-78.

Wolkoff P, Clausen PA, Nielsen PA, Møhlhave L. The Danish Twin Apartment Study: Part I: Formaldehyde and Long-Term VOC Measurements. *Indoor Air* 1991; 4: 478-490.

Wolkoff P. Volatile Organic Compounds – Sources, Measurements, Emissions, and the impact on Indoor Air Quality. *Indoor Air (Supplement)* 1995; 1: 9-73.

Wolkoff P, Clausen PA, Wilkins CK, Nielsen GD. Formation of Strong Airway Irritants in Terpene/Ozone Mixtures. *Indoor Air* 2000; 10: 82-91.

Wolkoff P, Nielsen GD. Organic Compounds in Indoor Air - Their Relevance for Perceived Indoor Air Quality. *Atmos Environ* 2001; 35: 4407-4417.

Won D, Corsi RL, Rynes M. Sorptive Interactions between VOCs and Indoor Materials. *Indoor Air* 2001; 11: 246-256.

Yang X, Chen Q, Zeng J, Zhang JS, Shaw CY. Effects of Environmental and Test Conditions on VOC Emissions from “Wet” Coating Materials. *Indoor Air* 2001; 11: 270-278.

Zhang J, He Q, Liou PJ. Characteristics of Aldehydes: Concentrations, Sources, and Exposures for Indoor and Outdoor Residential Microenvironments. *Environ Sci Technol* 1994; 28: 146-152.

Zhu JP, Zhang JS, Shaw CY. Comparison of Models for Describing Measured VOC Emissions from Wood-based Panels under Dynamic Chamber Test Condition. *Chemosphere* 2001; 44: 1253-1257.